

BLK BOX

Smith Machine

Setup Instructions

 CAUTION: Read all precautions and instructions before using this equipment. Save this manual for future reference.



Table Of Contents

Assembly Instructions.....02-07

Part List.....08

To Apply Thread Locker

The Fasteners marked by the sign  in the following assembling steps need to be bonded to prevent loosening, or the fasteners are a type of thread locking screws.

How to use

1. Degrease and clean surfaces prior to apply adhesive.
2. Insert bolt and apply adhesive to the exposed thread. Assemble nut and tighten to the correct torque (FIG 1).
3. Apply several drops of adhesive down the sides of the blind hole filling the lower third. Apply several drops to the bolt, Assemble and tighten (FIG 2).

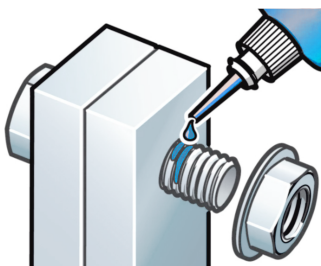

FIG 1

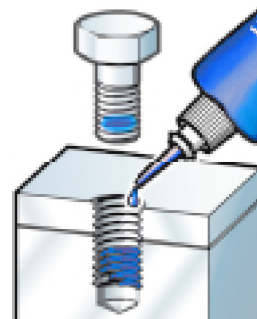
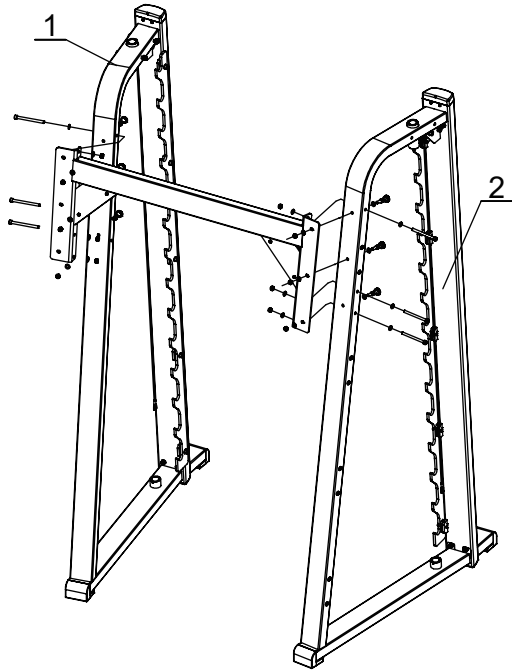

FIG 2

STEP 1



Parts

Part No: 1
Name: Main Frame
Q'TY: 1

Part No: 2
Name: Main Frame 2
Q'TY: 1

Part No: 3
Name: Back Connection Tube Assy
Q'TY: 1

Part No: 4
Name: Hole Cap
Q'TY: 6

Fixings

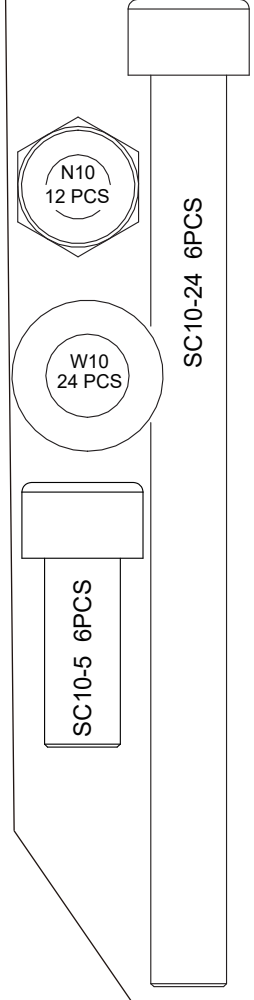

Tools

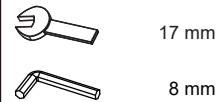

Connect The Main Frame(#1) And The Main Frame 2(#2) With The Back Connection Tube Assy (#3).

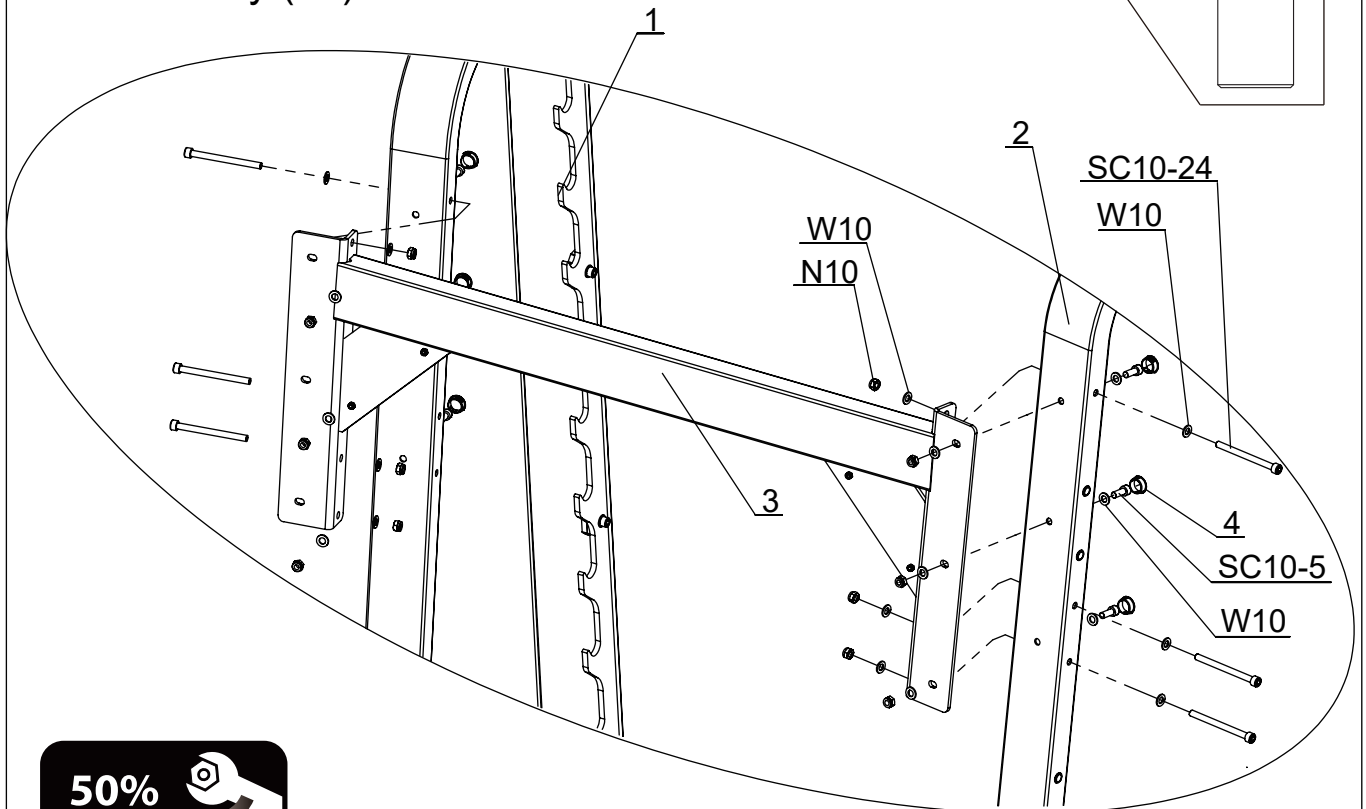

50%



Fixings

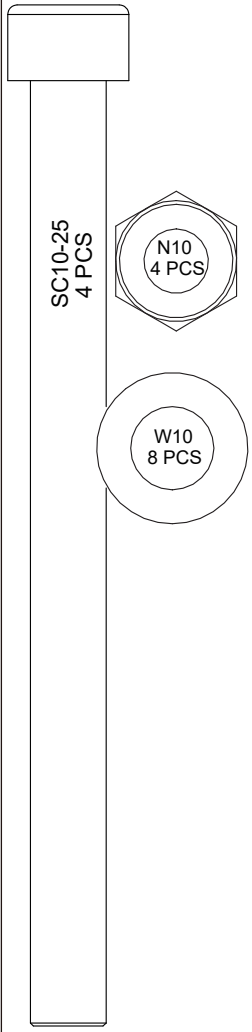

Parts

Part No: 5
Name: Front Connection Tube Assy
Q'TY: 1

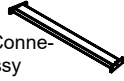

Tools



STEP 2

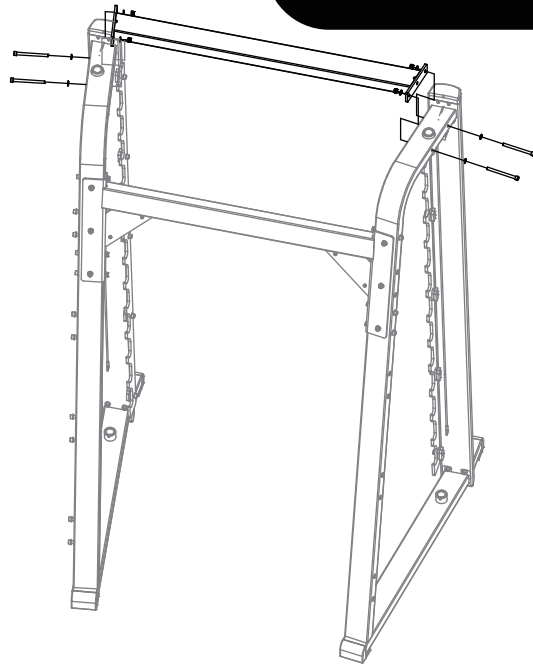

Install The Front Connection Tube Assy(#5).

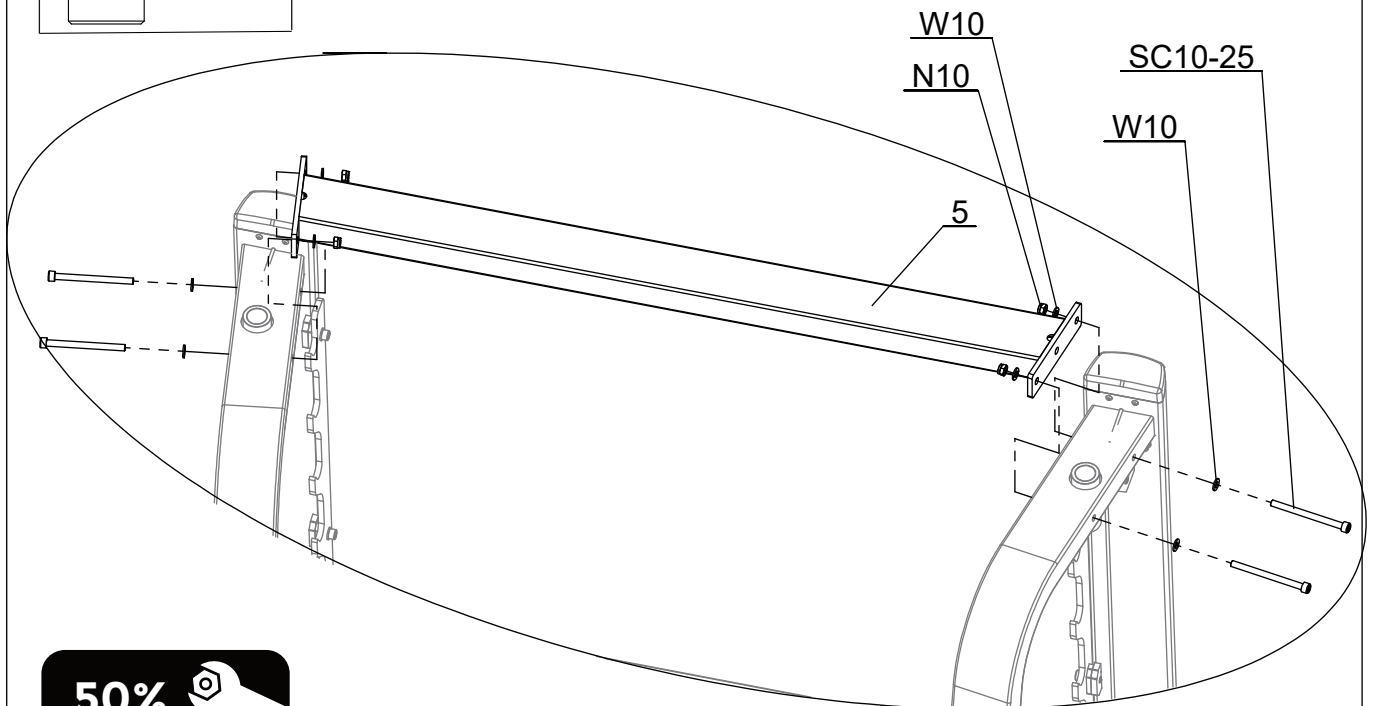

50%



STEP 3

Fixings



S6-2
2 PCS

Parts

Part No: 6
Name: Guide Rod
Q'TY: 2



Part No: 7
Name: Limit Ring
Q'TY: 2



Part No: 8
Name: Buffer Ring
(minimum ID 29.8 mm)



Part No: 9
Name: Buffer Ring
(minimum ID 30.5mm)
Q'TY: 2



Part No: 10
Name: Safe Hook
Q'TY: 2



Part No: 11
Name: Weight Bar
Q'TY: 1



Part No: 12
Name: Barbell Clip
Q'TY: 2



Tools



3 mm

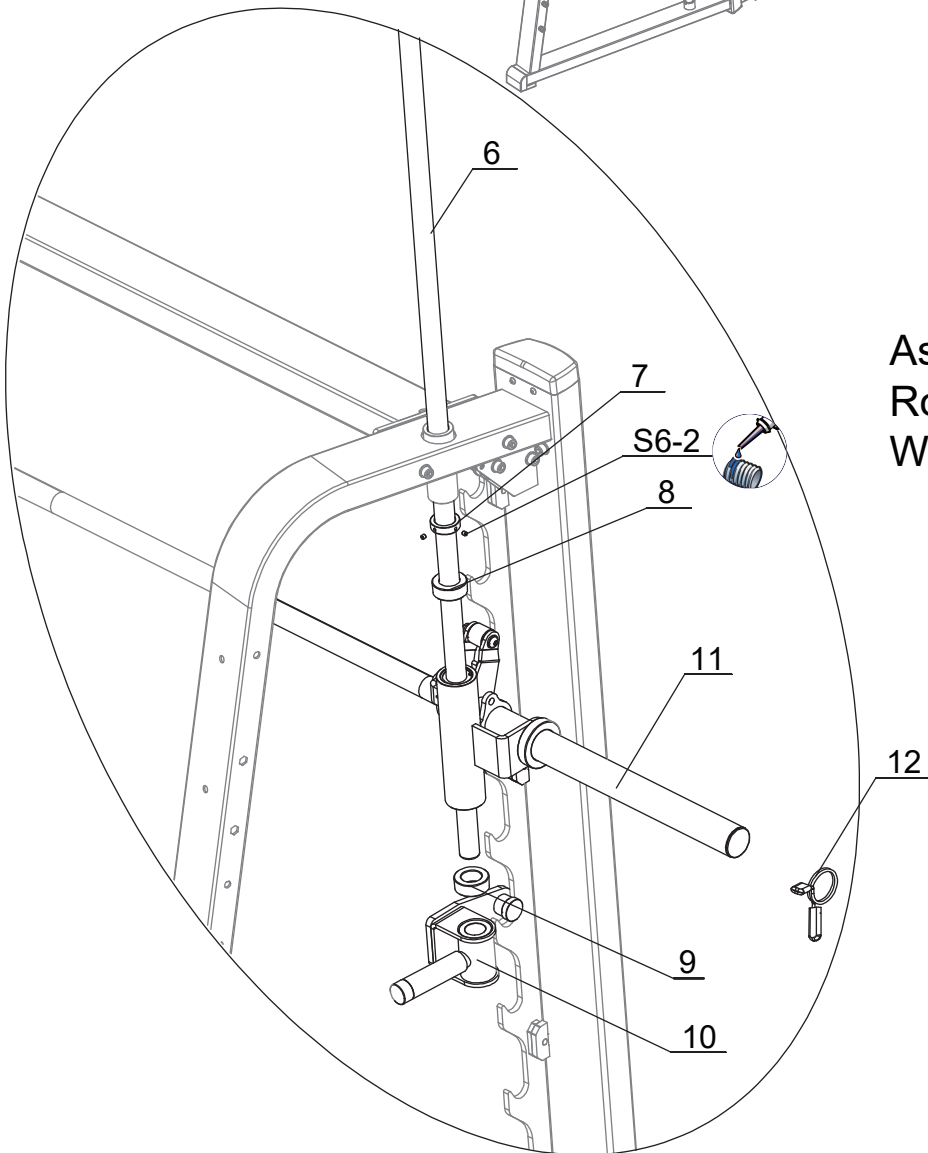
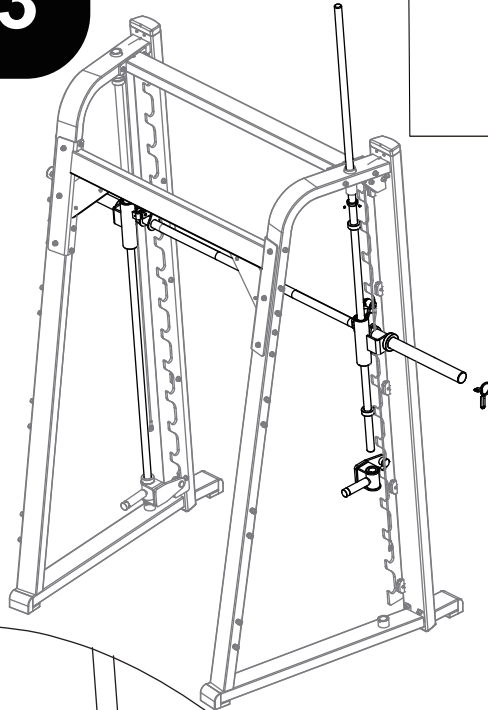

Assemble The Guide Rod(#6) And The Weight Bar(#11).

50%



STEP 4

Fixings

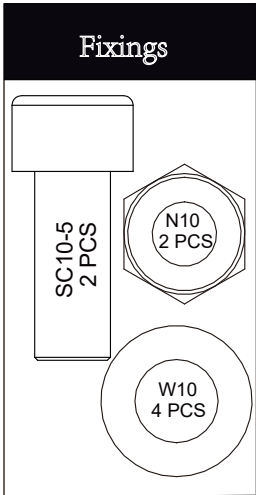

- SC10-5
2 PCS
- N10
2 PCS
- W10
4 PCS

Tools

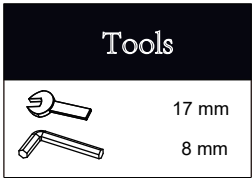

- 17 mm
- 8 mm

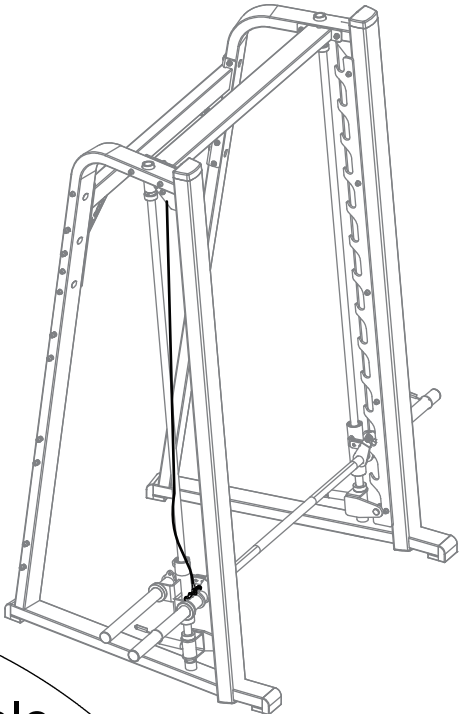

Install The Cable.

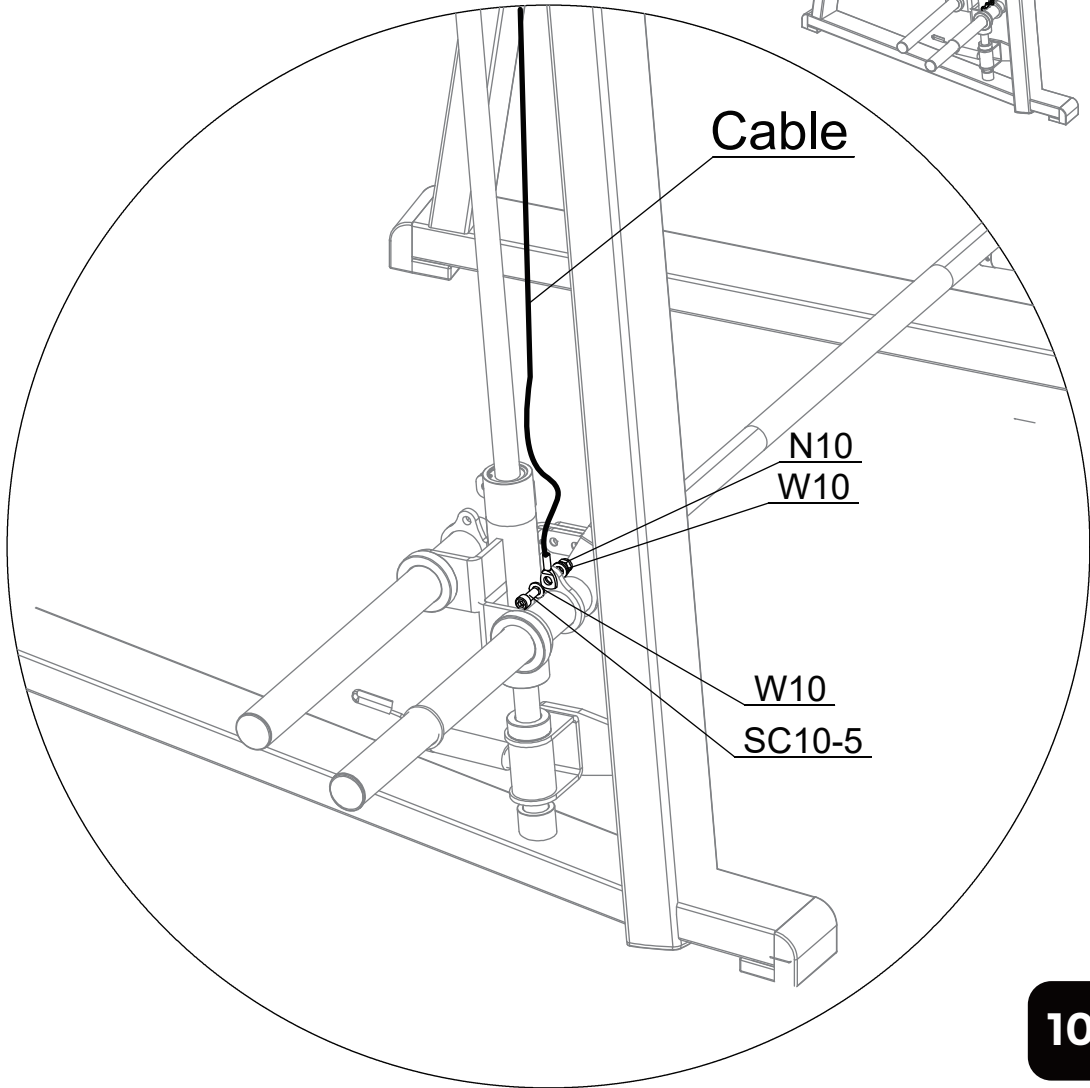

STEP 5

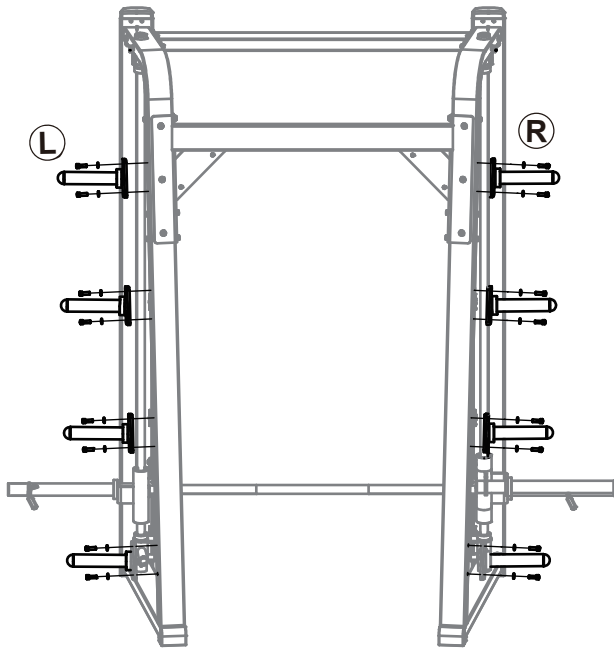

Parts

Part No: 13
Name: Barbell Holder 1
Q'TY: 4



Part No: 14
Name: Barbell Holder 2
Q'TY: 4



Fixings

SC10-6
16 PCS

W10
16 PCS

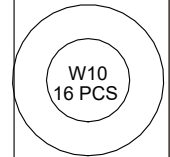

Tools



8 mm

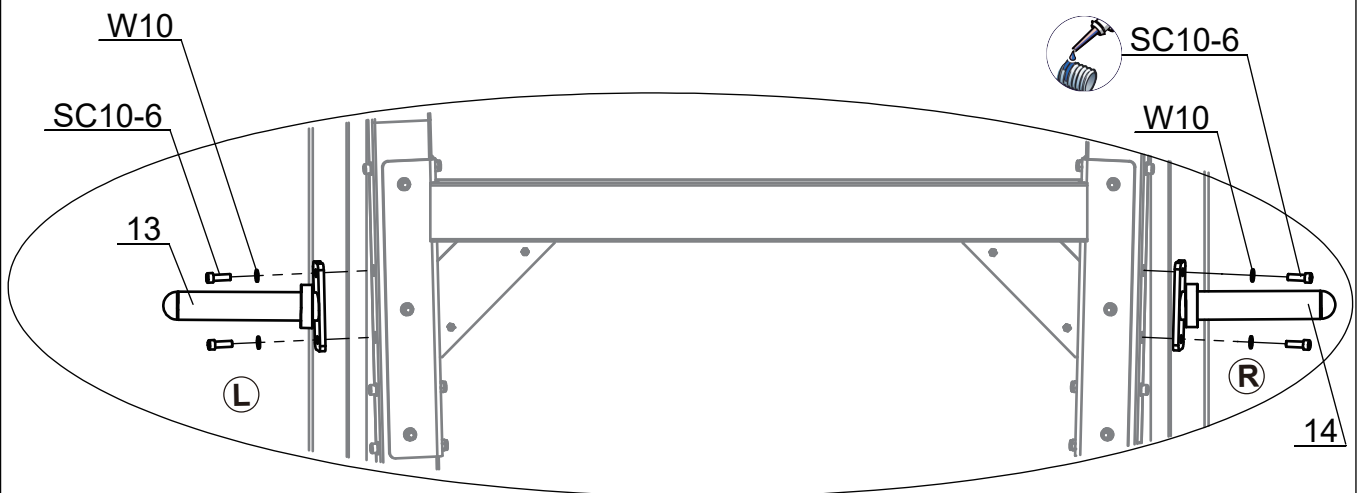

Install the Barbell Holder (#13 & #14).



PARTS LIST

PART#	DESCRIPTION	QTY
1	Main Frame 1	1
2	Main Frame 2	1
3	Back Connection Tube Assy	1
4	Hole Cap	6
5	Front Connection Tube Assy	1
6	Guide Rod	2
7	Limit Ring	2
8	Buffer Ring(minimum ID 29.8 mm)	2
9	Buffer Ring(minimum ID 30.5mm)	2
10	Safe Hook	2
11	Weight Bar	1
12	Barbell Clip	2
13	Barbell Holder 1	4
14	Barbell Holder 2	4
N10	Nut M10	18
S6-2	Socket Set Screw M6X6	22
SC10-5	Socket Head Cap Screw M10 × 25	8
SC10-6	Socket Head Cap Screw M10 × 30	16
SC10-24	Socket Head Cap Screw M10 × 120	6
SC10-25	Socket Head Cap Screw M10 × 125	4
W10	Washer Φ10	52