

# BLK BOX

## Pin Select Chin/Dip Assist

### Setup Instructions

 CAUTION: Read all precautions and instructions before using this equipment. Save this manual for future reference.

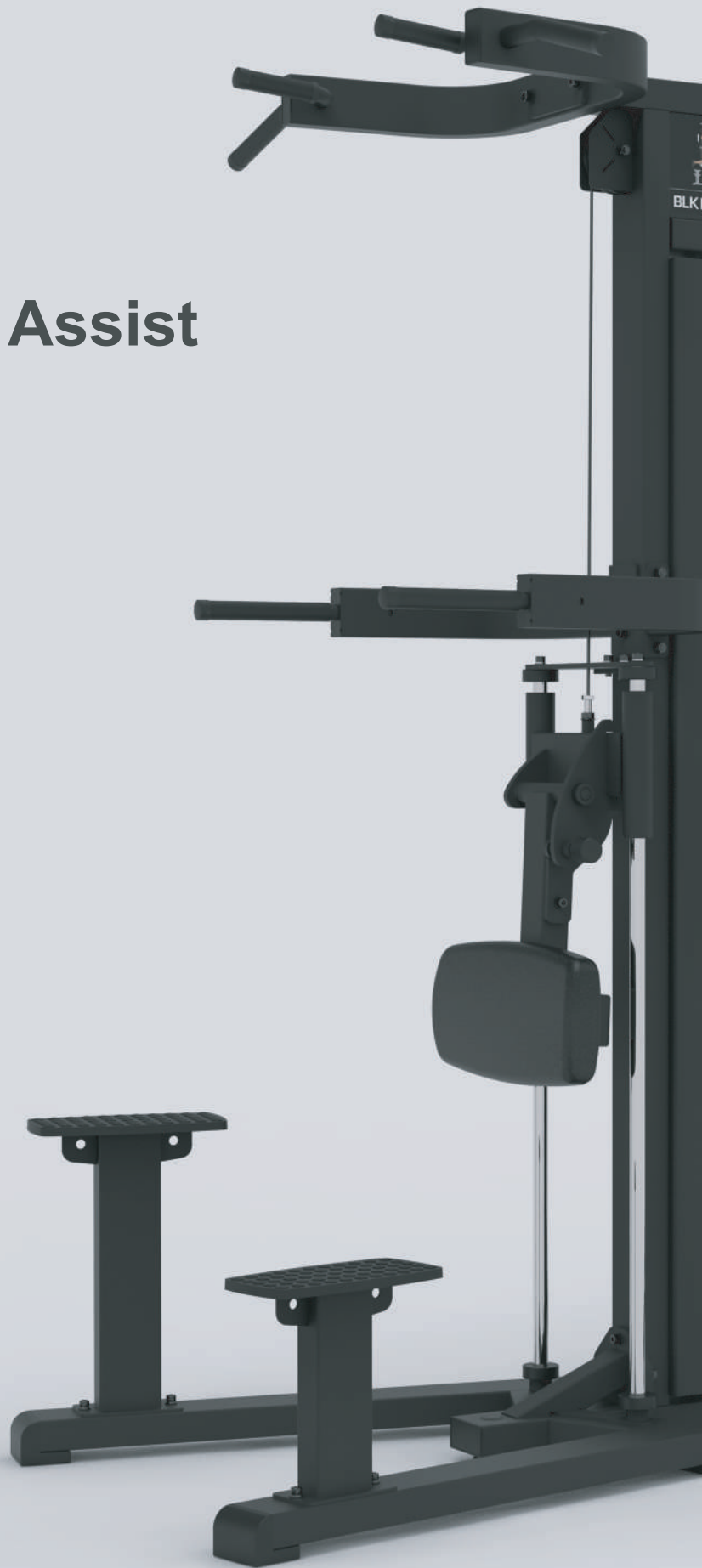
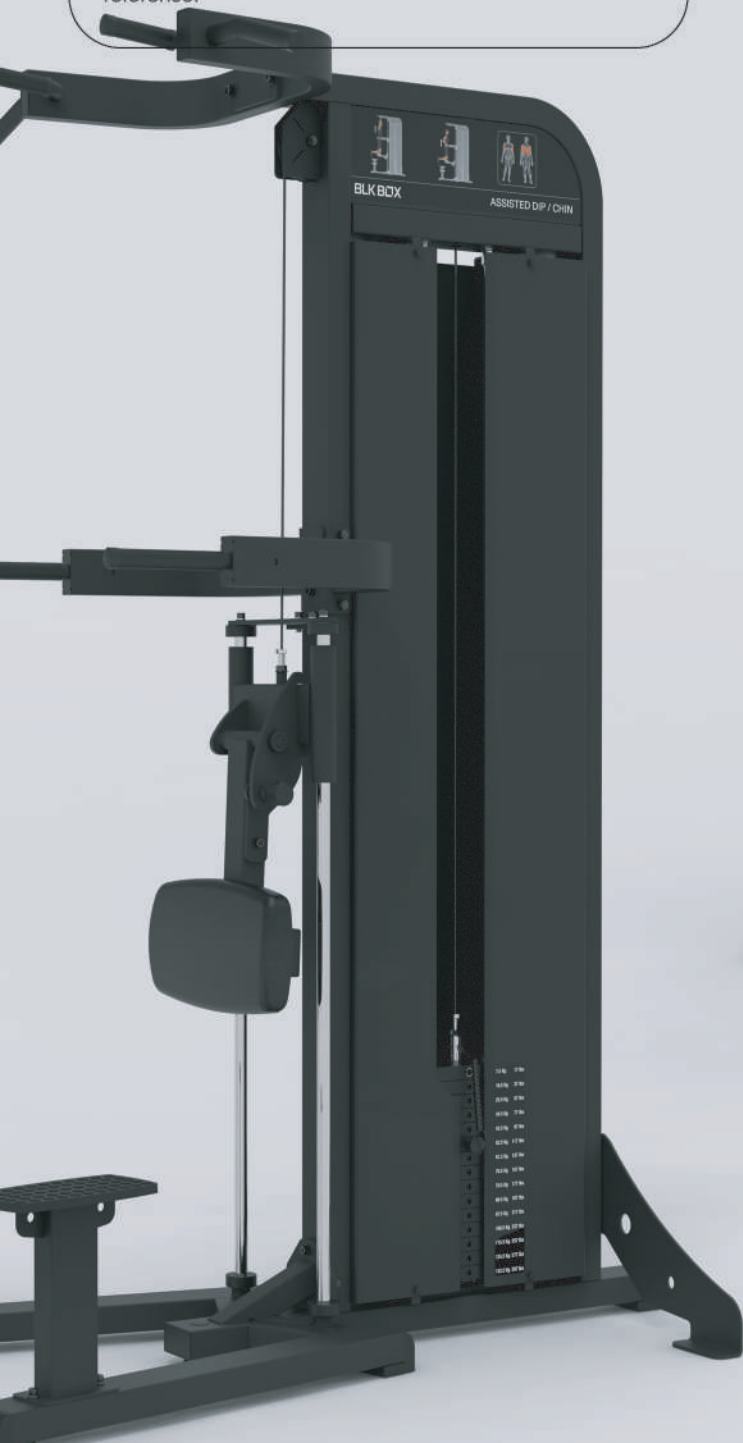

# Table Of Contents

Assembly Instructions.....	2-14
Part List.....	15

# To Apply Thread Locker

The Fasteners marked by the sign  in the following assembling steps need to be bonded to prevent loosening, or the fasteners are a type of thread locking screws.

## How to use

1. Degrease and clean surfaces prior to apply adhesive.
2. For through hole , insert bolt and apply adhesive to the exposed thread. Assemble nut and tighten to the correct torque (FIG 1).
3. Apply several drops of adhesive down the sides of the blind hole filling the lower third. Apply several drops to the bolt, Assemble and tighten (FIG 2).

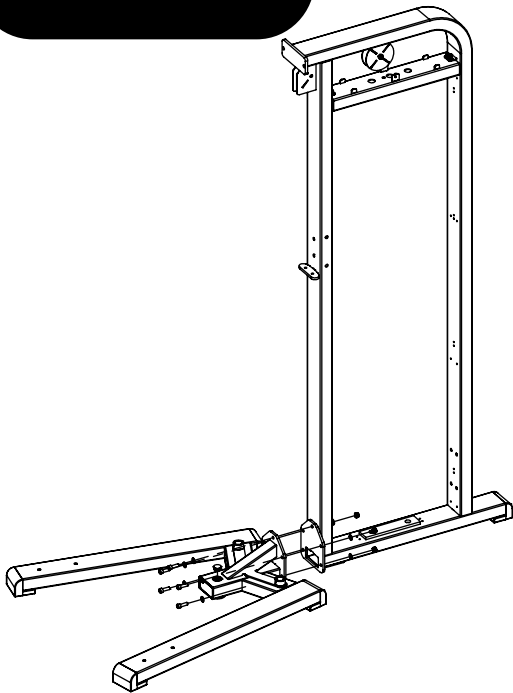

**FIG 1**



**FIG 2**

# STEP 1



## Parts

Part No: 1  
Name: Main Frame  
Q'TY:1



Part No: 2  
Name: Bottom Frame  
Q'TY:1



Part No: 18  
Name: D25 Cap  
Q'TY:1



## Fixings

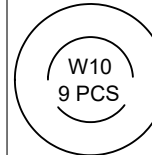
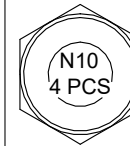

SC10-6 5 PCS

## Tools



8 mm

Assemble Main Frame(#1) And The Bottom Frame(#2).

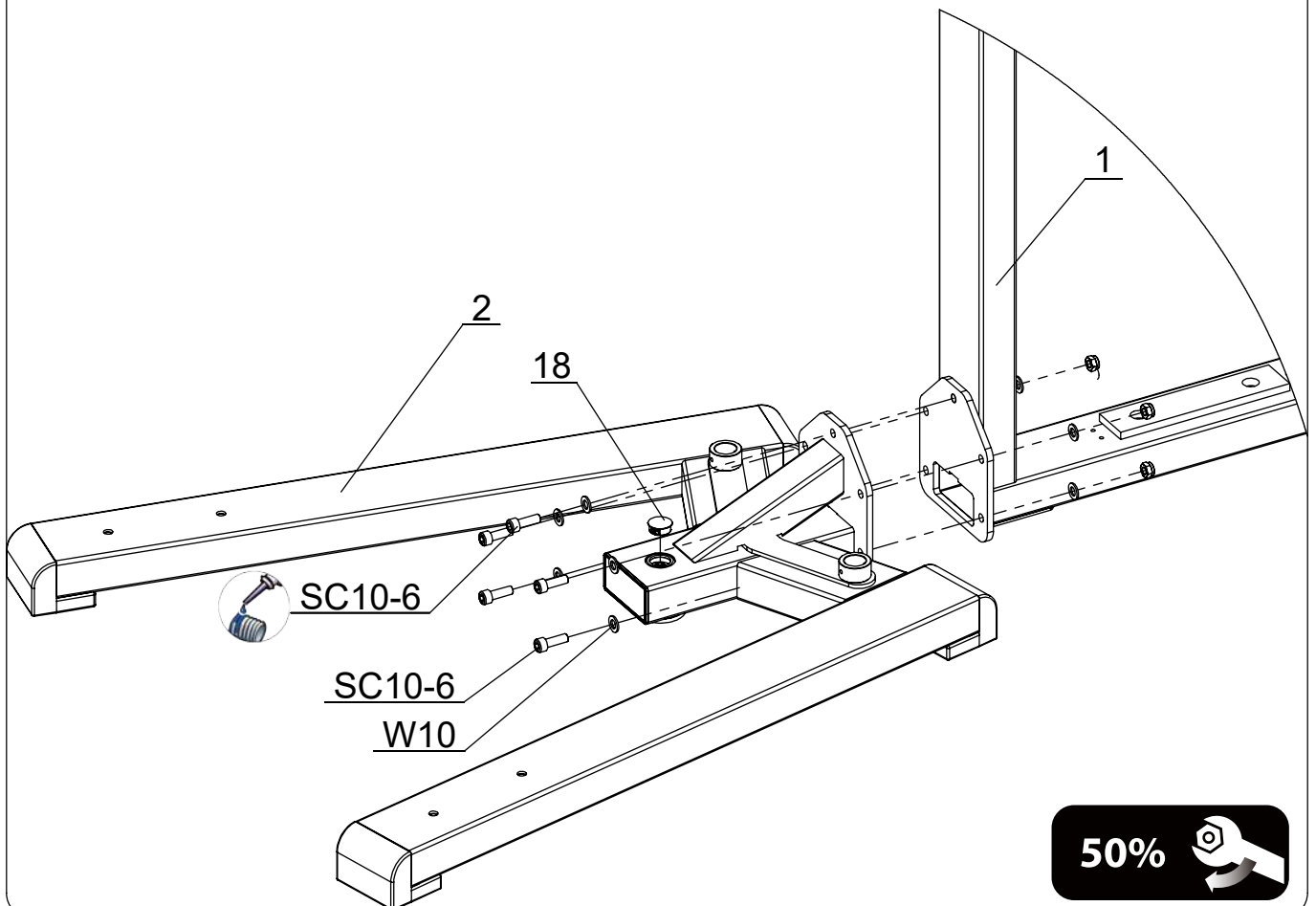

50%



# STEP 2

## Parts

Part No:3  
Name: Brace  
Q'TY:1



## Tools



8 mm

## Fixings

SC10-5 4 PCS

SW10  
4 PCS

W10  
4 PCS

Install The Plate Brace(#3).

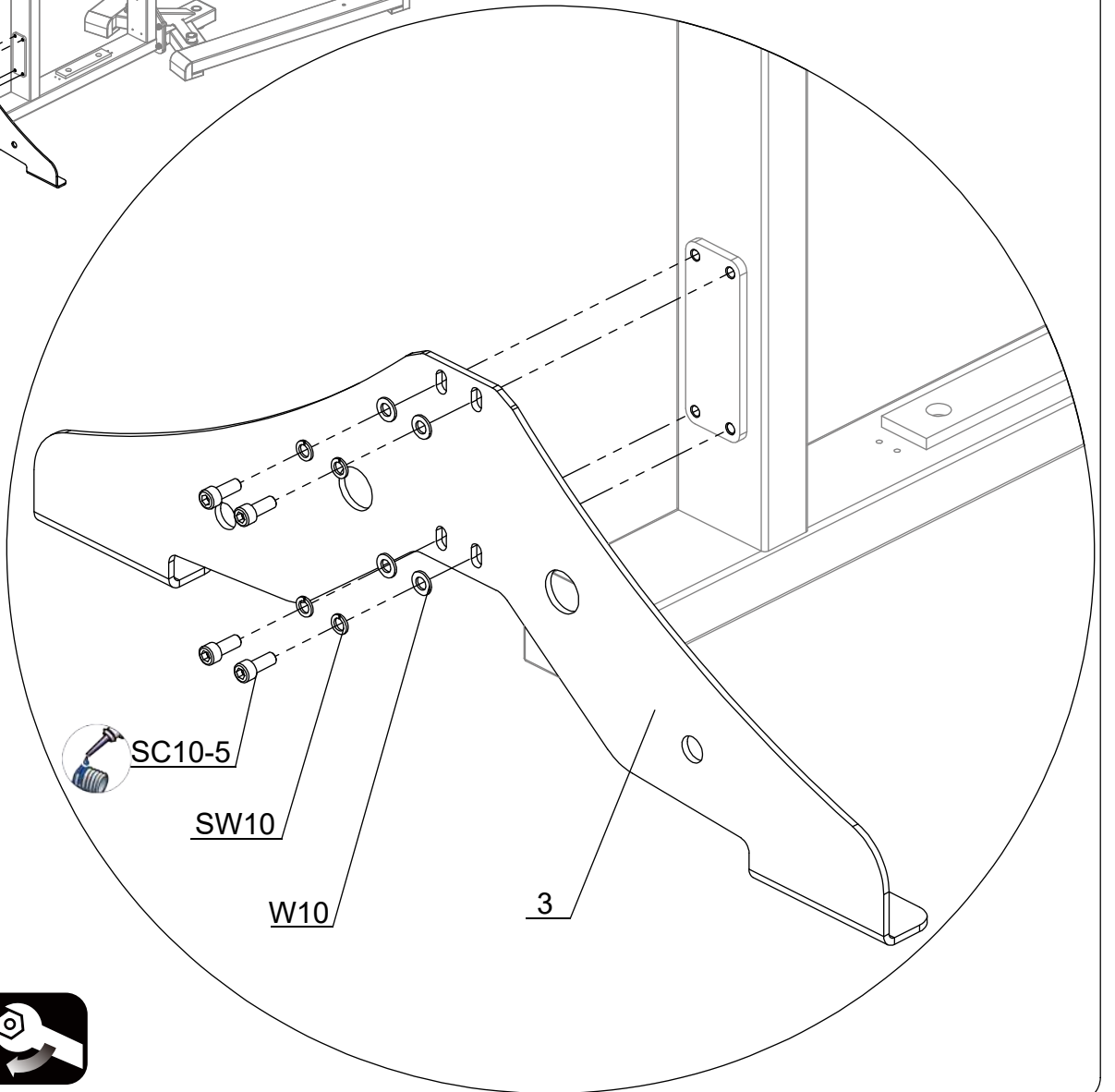
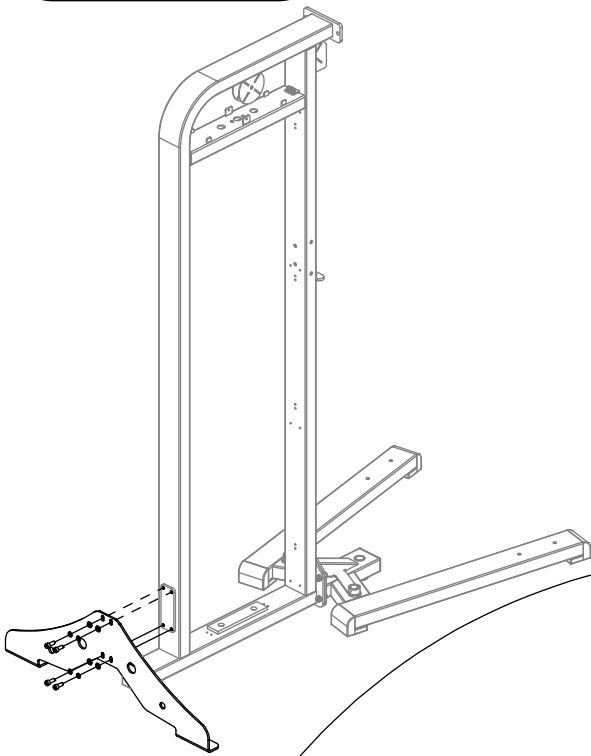

50%



# STEP 3

## Parts

Part No:4  
Name:  
Shield Support  
Q'TY:4



## Fixings

W 6  
8 PCS

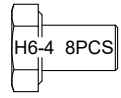

H6-4 8PCS

## Tools



10 mm

Install The Shield Support (#4).

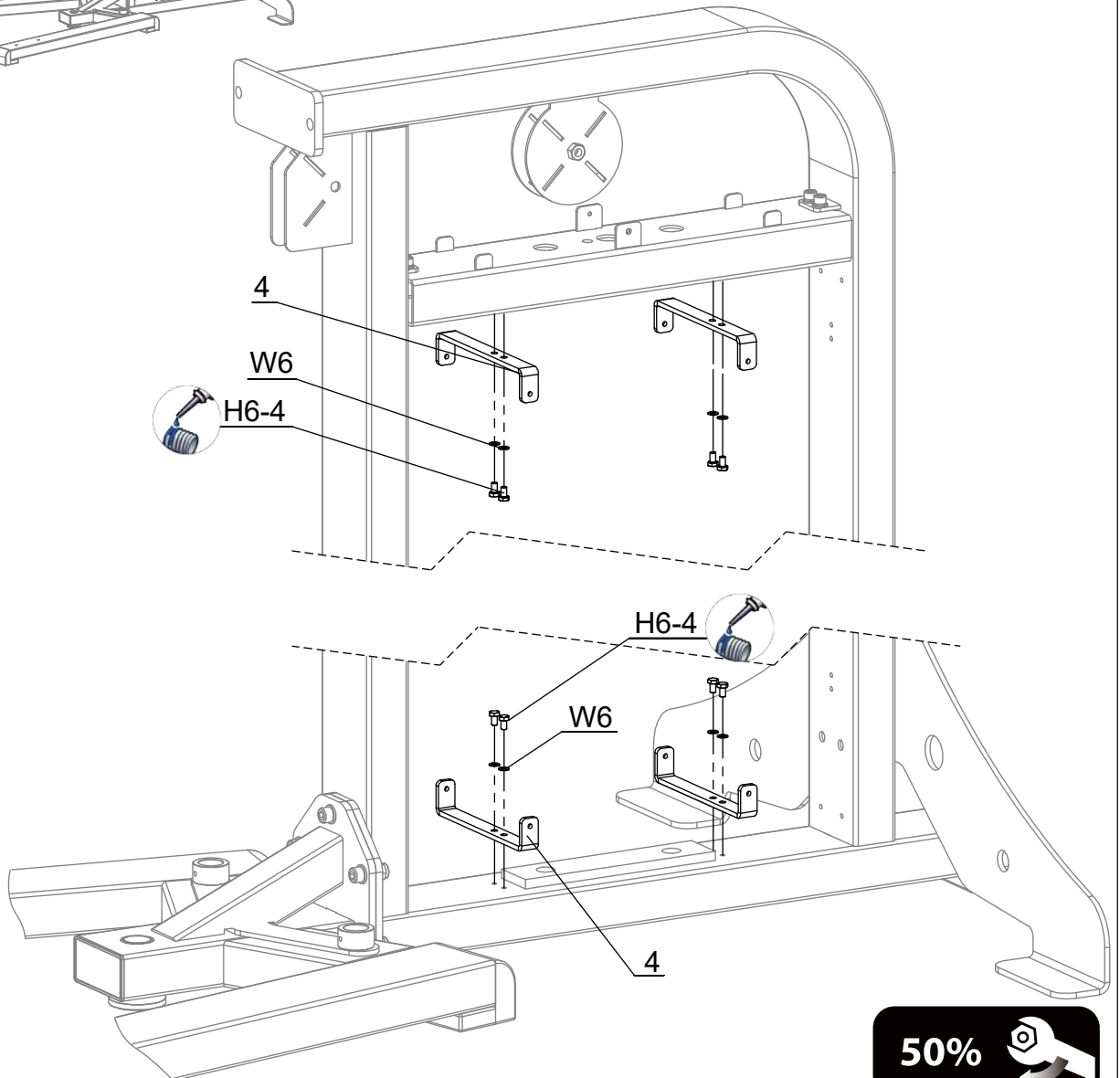
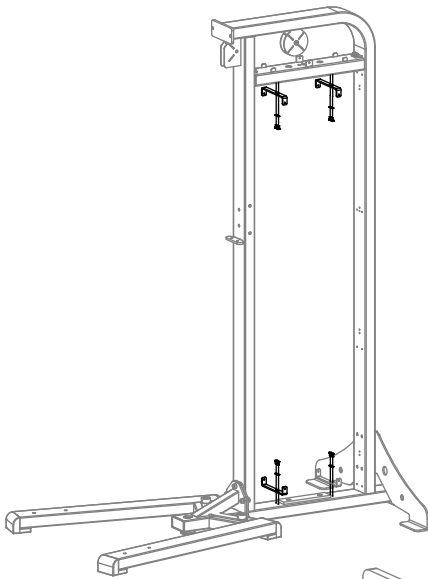

# STEP 4

## Tools

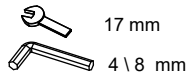

## Fixings

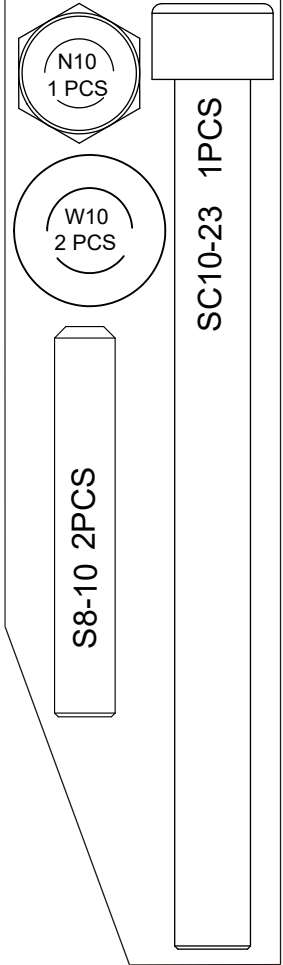

Assemble The Weight Stack.

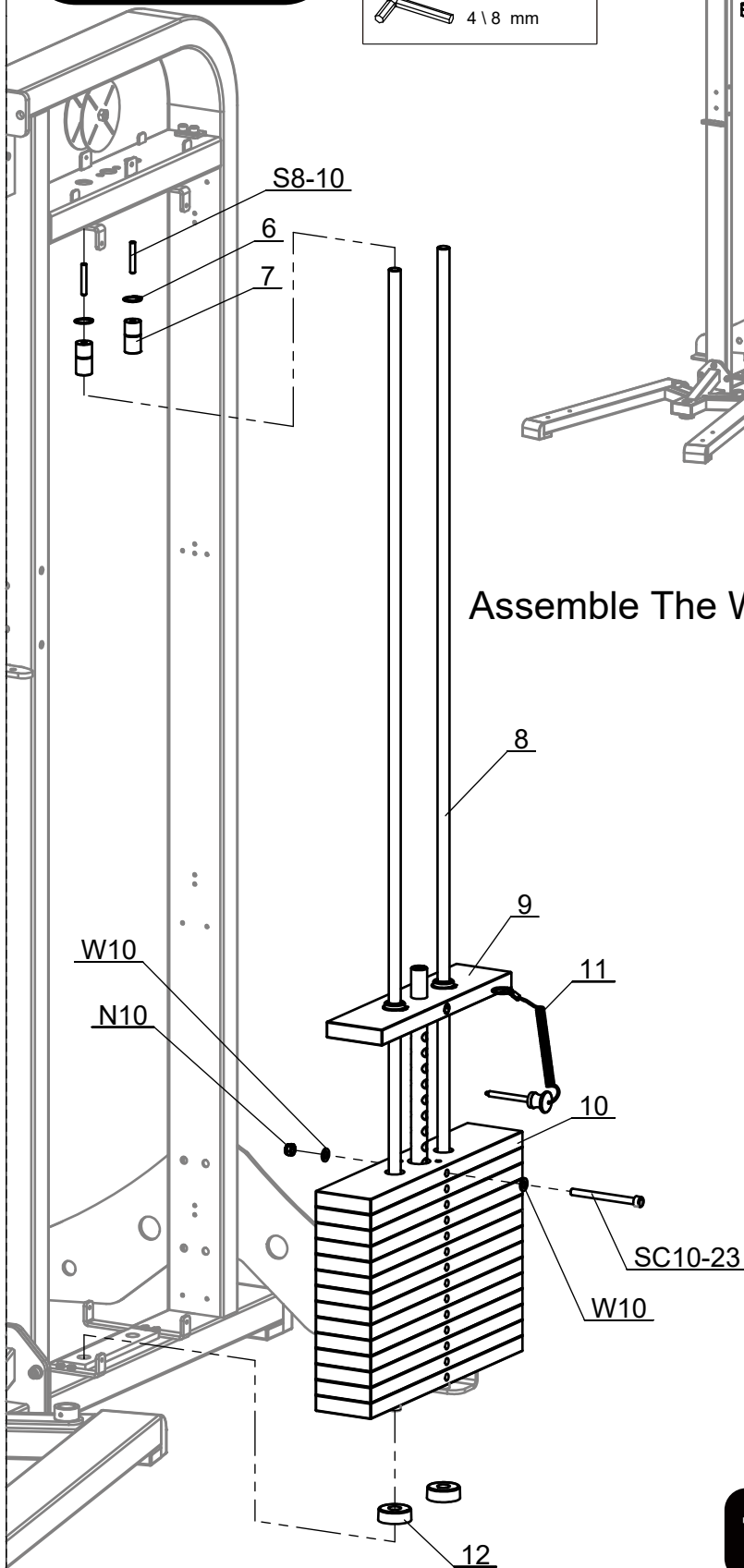

## Parts

Part No:7	Name: Rod Retainer	
Q'TY:2		
Part No:6	Name:Retainer Ring	
Q'TY:2		
Part No:8	Name:Guide Rod	
Q'TY:2		
Part No:9	Name:Top Weight - Selector	
Q'TY:1		
Part No:10	Name:5Kg Weight Plate	
Q'TY:6		
Part No:11	Name:Weight Pin	
Q'TY:7		
Part No:12	Name: Buffer Ring ID19	
Q'TY:2		





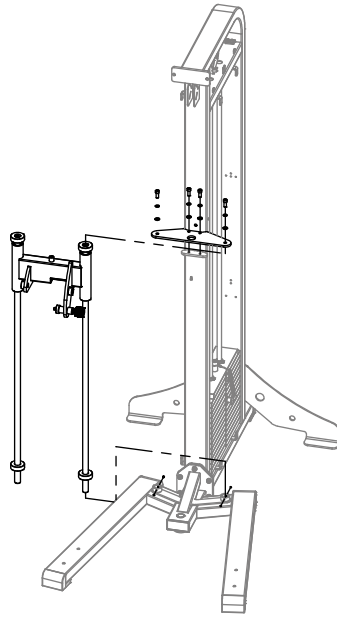

# STEP 5

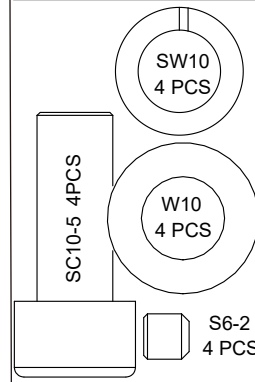

## Fixings

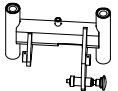

## Parts

- Part No:13   
Name:Fixing Plate  
Q'TY:1
- Part No:14   
Name: D24.8 Buffer Ring  
Q'TY:2
- Part No:15   
Name:Guide Rod D25  
Q'TY:2
- Part No:16   
Name:Sliding Frame  
Q'TY:1
- Part No:17   
Name: D25.5 Buffer Ring  
Q'TY:2

Assemble The Sliding Frame(#16)  
And The Guide Rod(#15).

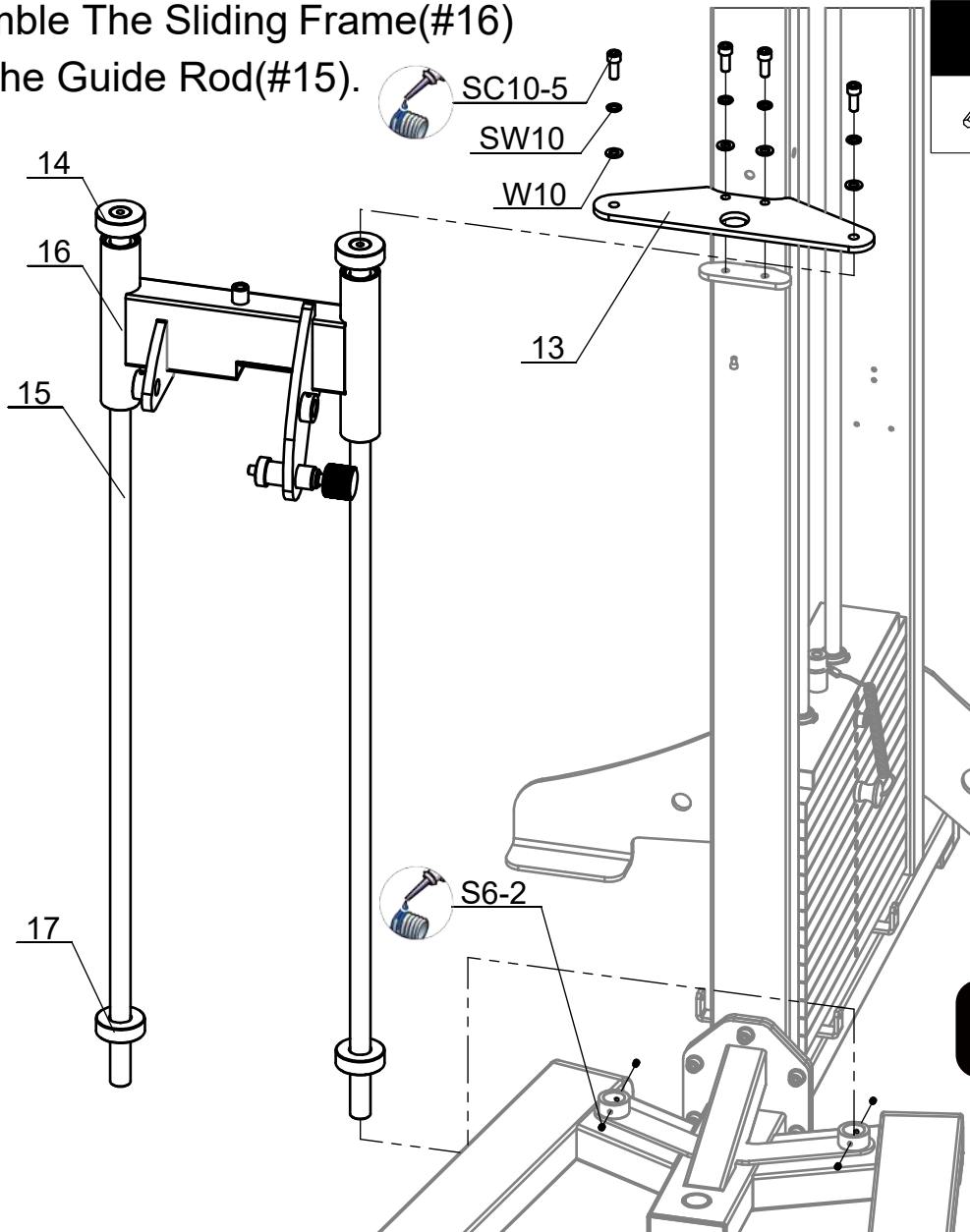

## Tools



50%



# STEP 6

Assemble The 114 Pulley(#19) ,And The Cable(#20).

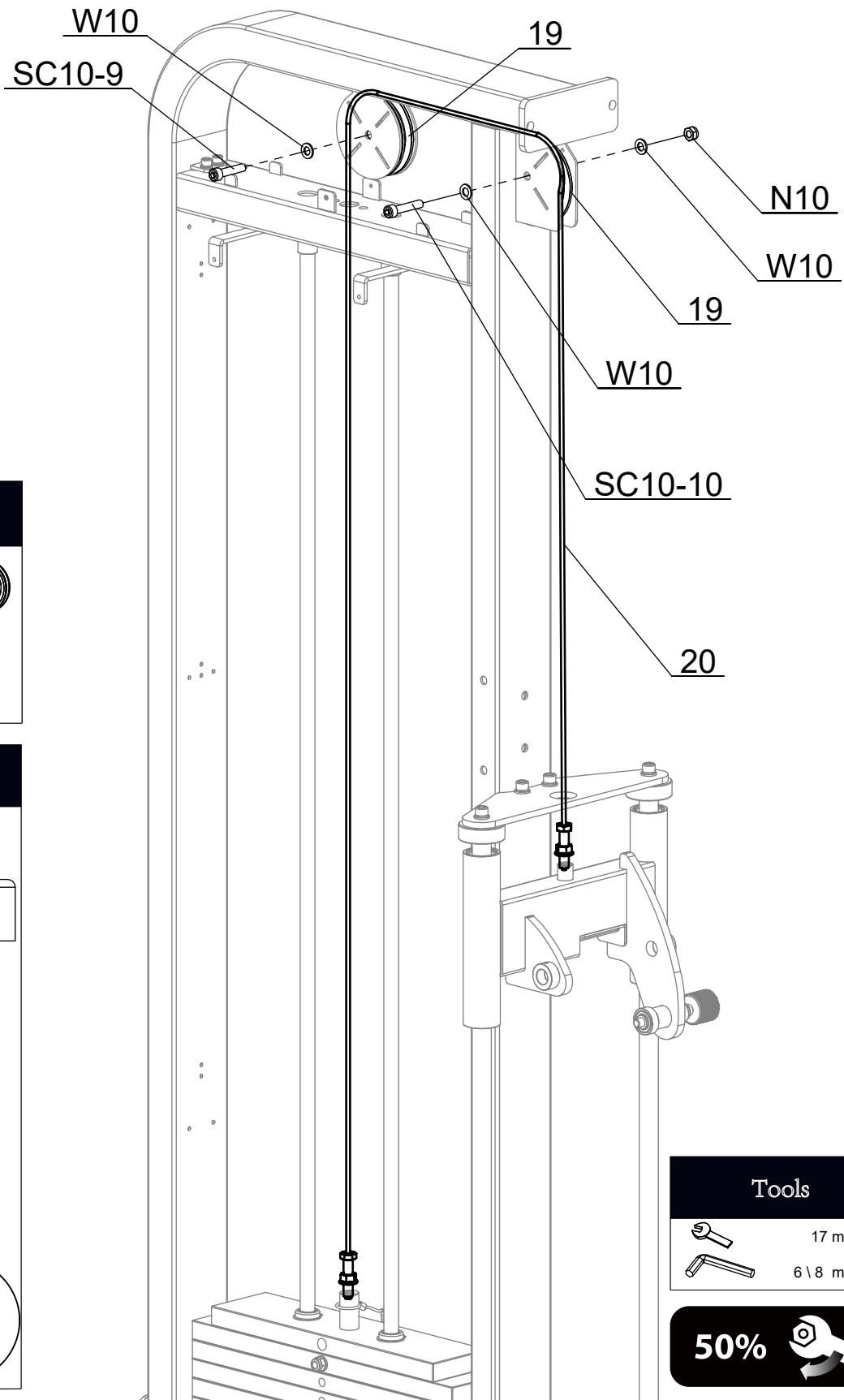

## Parts

Part No:19  
Name: 114 Pulley  
Q'TY:2



Part No:20  
Name: Cable  
Q'TY:1



## Fixings

SC10-10 1PC

SC10-9 1PC

N10  
1 PC

W10  
3 PCS

## Tools



17 mm



6 \ 8 mm

50%



# STEP 7

## Tools



3/8 mm

## Parts

Part No:18  
Name: D25 Cap  
Q'TY: 2



Part No: 21  
Name: Cushion Holding  
Frame  
Q'TY: 1



Part No:22  
Name: Shaft  
Q'TY: 1



Part No:23  
Name: Knee Cushion  
Q'TY: 1



## Fixings

S6-3

2 PCS

W8

2 PCS

SC8-6 2 PCS

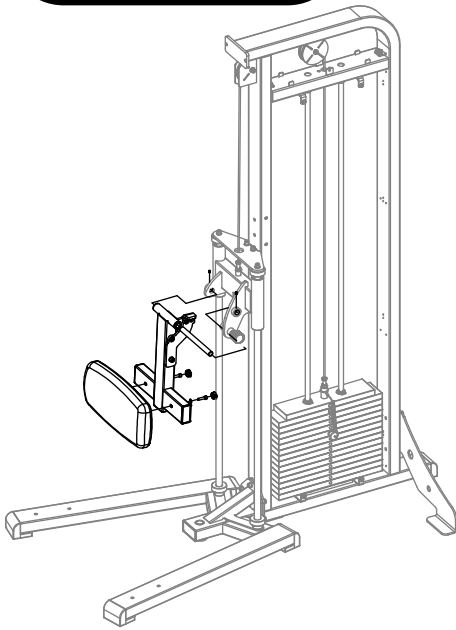

Assemble The Cushion Holding Frame(#21)  
And The Knee Cushion(#23).

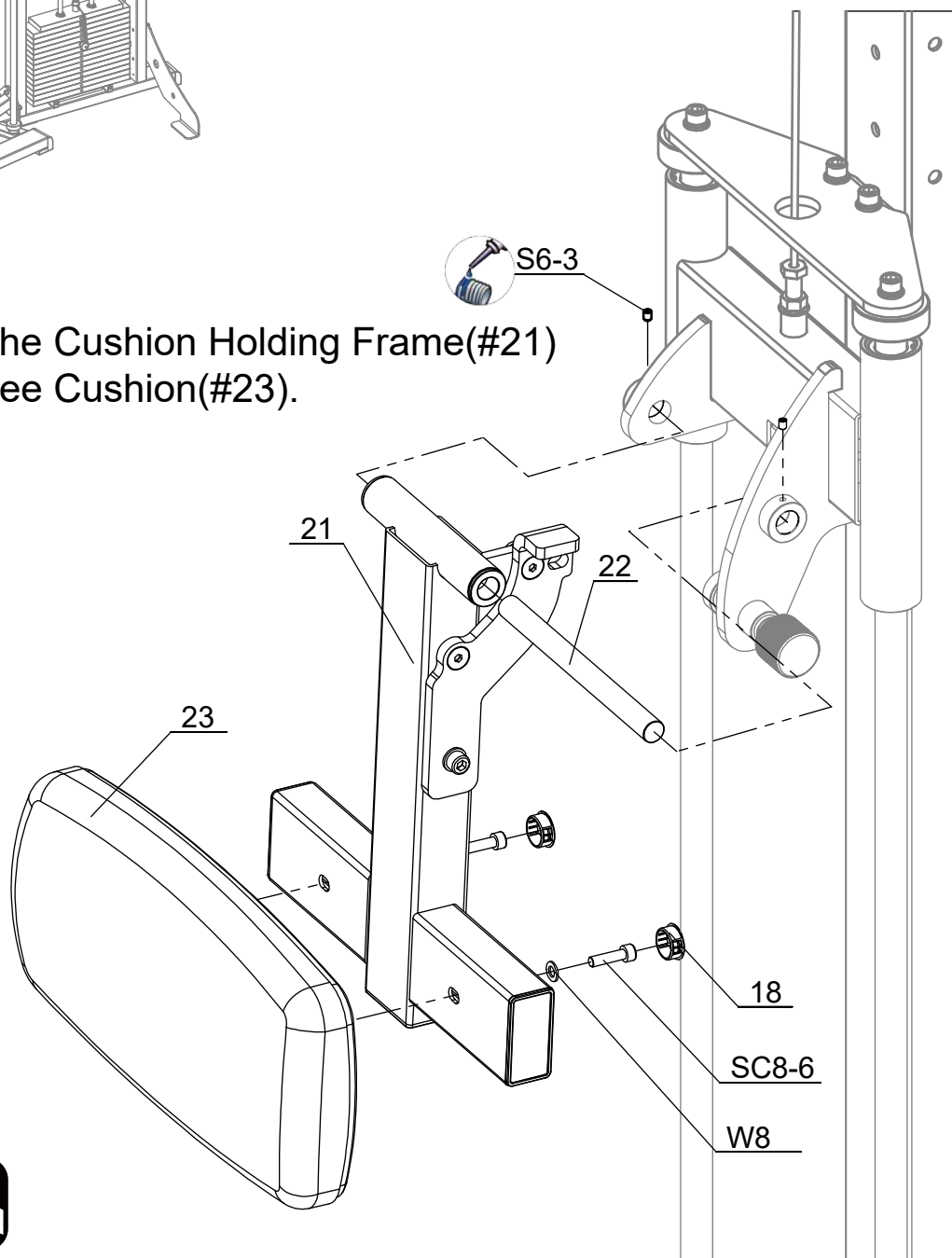

50%



# STEP 8

## Tools



8 mm

## Parts

Part No:25  
Name: Right Pedal  
Assy  
Q'TY:1



Part No:24  
Name: Left Pedal  
Assy  
Q'TY:1

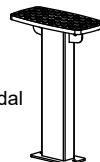

## Fixings

SW10  
4 PCS

W10  
4 PCS

SC10-5 4PCS

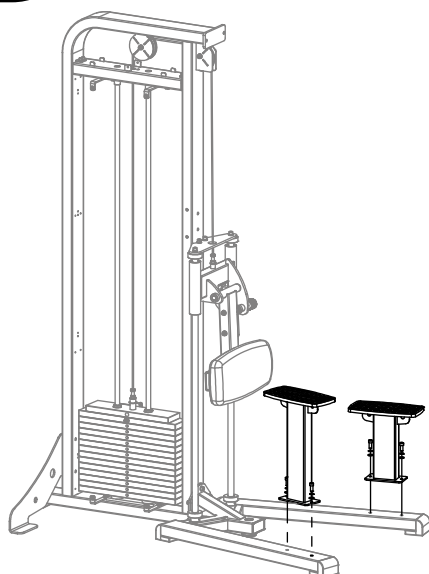

Assemble The Left Pedal(#24)  
And The Right Pedal(#25).

24

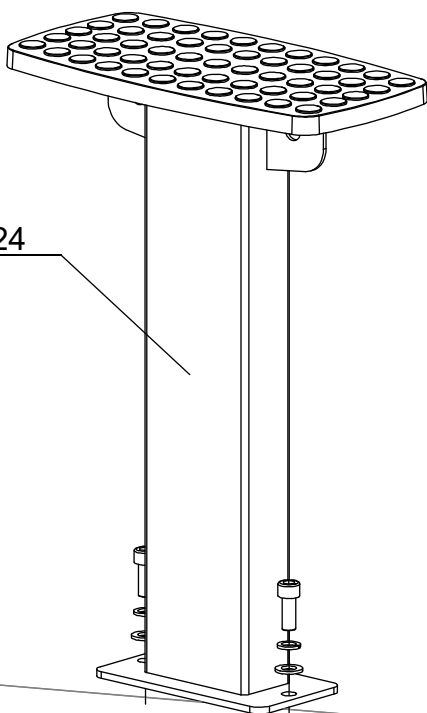

25

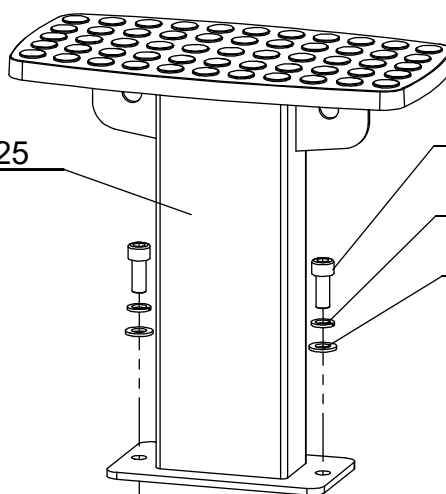

SC10-5

SW10

W10

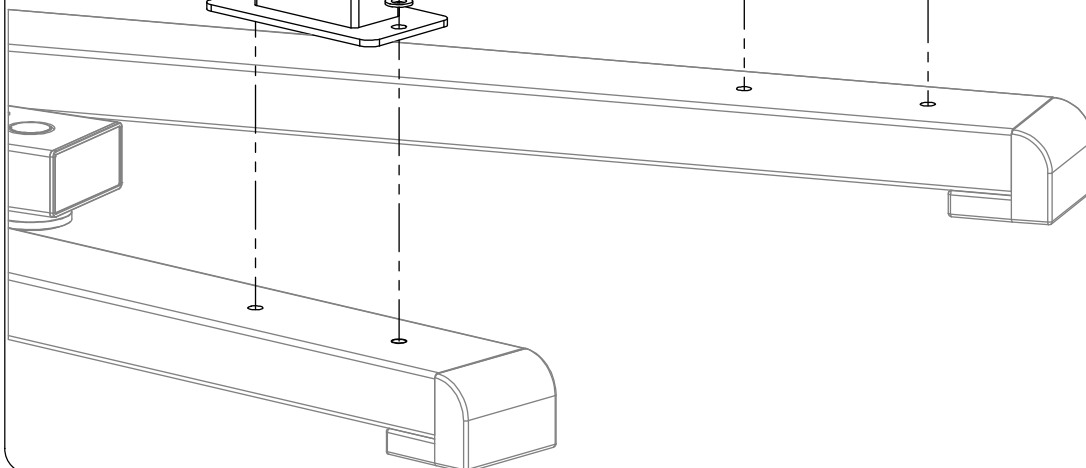

50%



# STEP 9

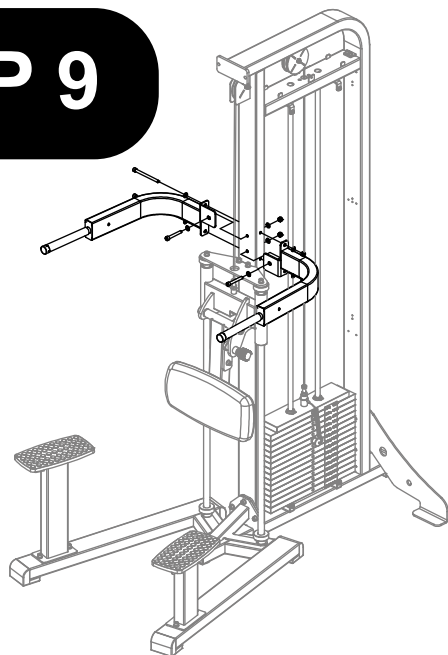

## Parts

Part No:26  
Name: Dip Arm  
Q'TY: 2

## Tools



8 mm



17 mm

## Fixings

SC10-14 2 PCS

SC10-25 2 PCS

N10  
4 PCS

W10  
8 PCS

Assemble The Dip Arm(#26).

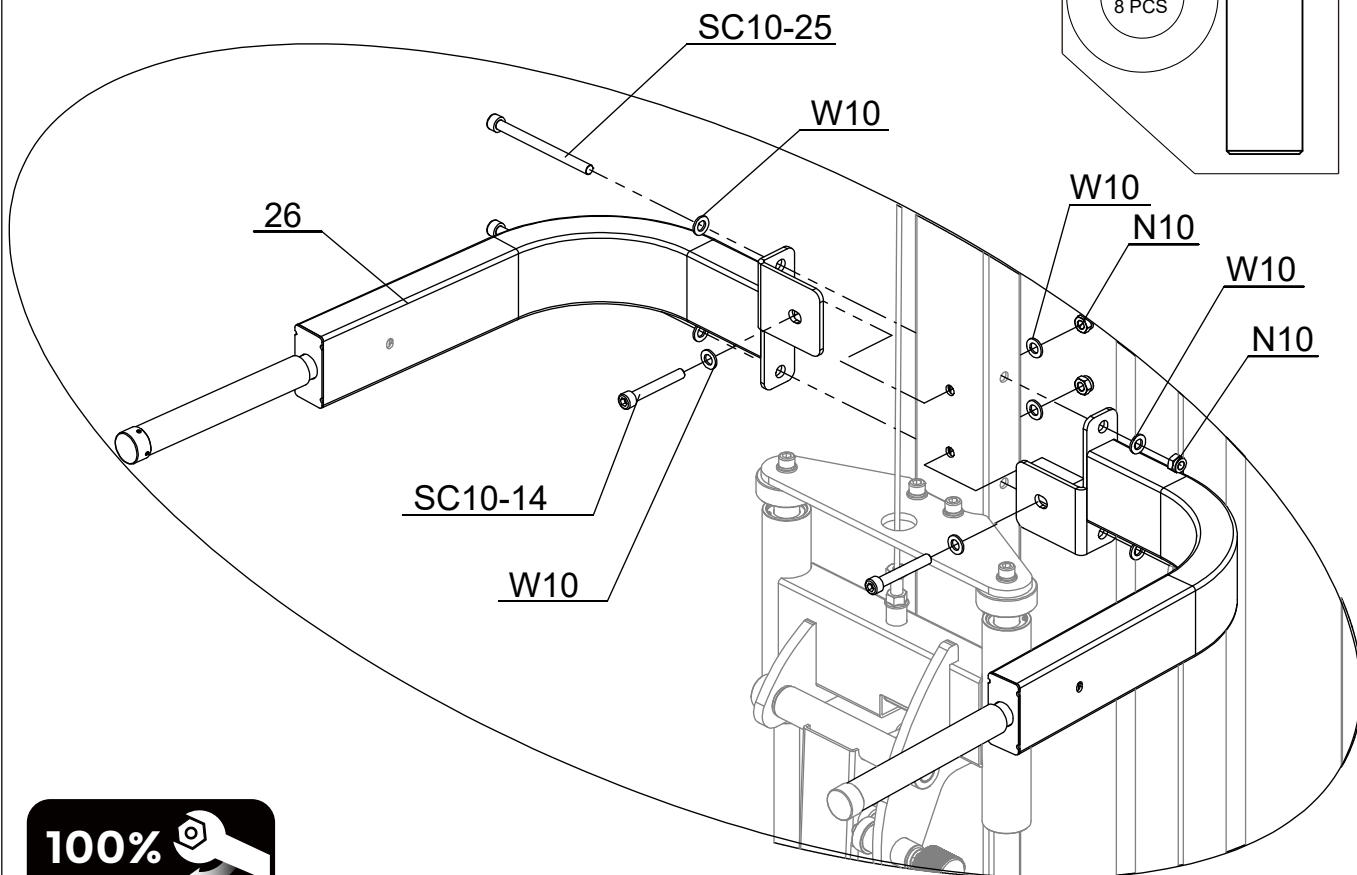



100%



# STEP 10

## Tools

-  10 mm
-  19 mm

## Parts

Part No:27  
Name:  
Handle Frame Holder  
QTY:1

## Fixings

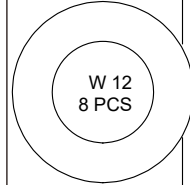
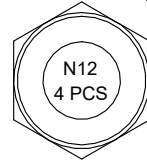

SC12-16 2 PCS

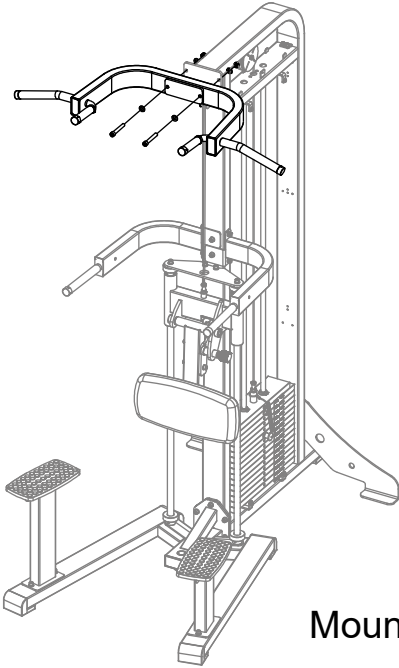

Mount The Handle Frame Holder(#27).

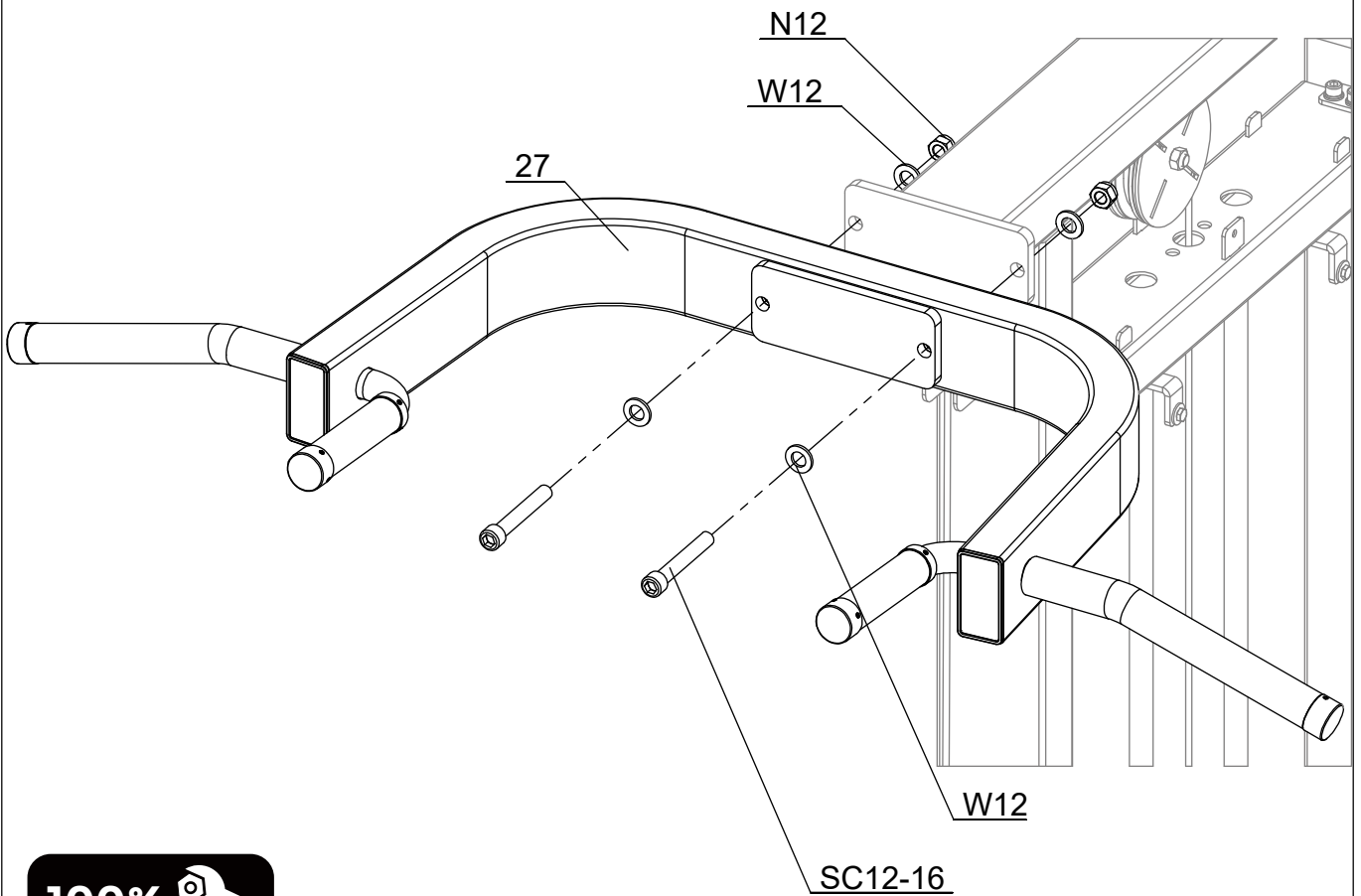

100%



# STEP 11

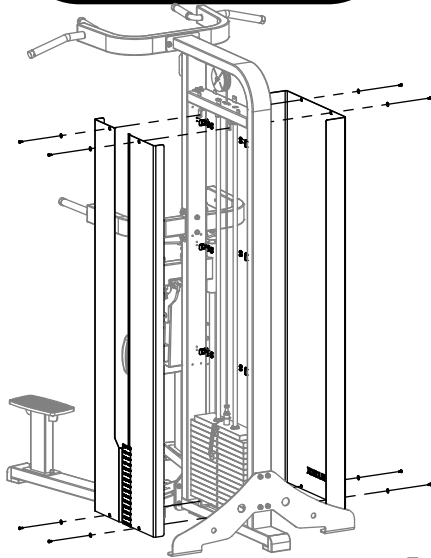

## Fixings



W6  
16 PCS



H6-4  
24 PCS

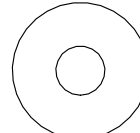

W6B  
8 PCS

## Tools



10 mm

## Parts

Part No:5  
Name: Clamp Plate  
Q'TY:8



Part No:28  
Name: Front Left  
Shield Plate  
Q'TY:1



Part No:29  
Name: Front Right  
Shield Plate  
Q'TY:1



Part No:31  
Name:  
Back Shield Plate  
Q'TY:1



Part No:30  
Name: Weight Label  
Q'TY:1



Assemble The Shield Plate.

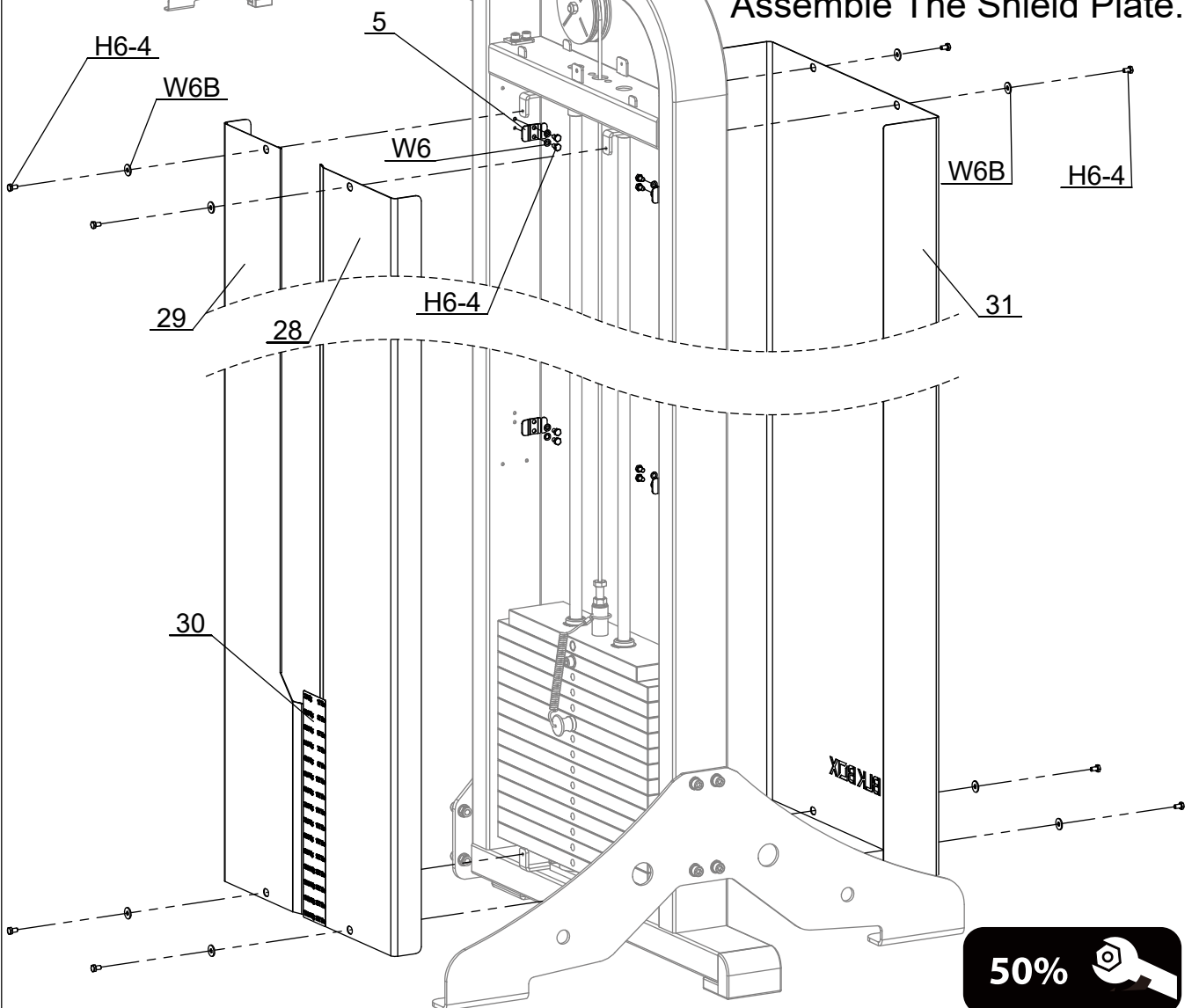

# STEP 12

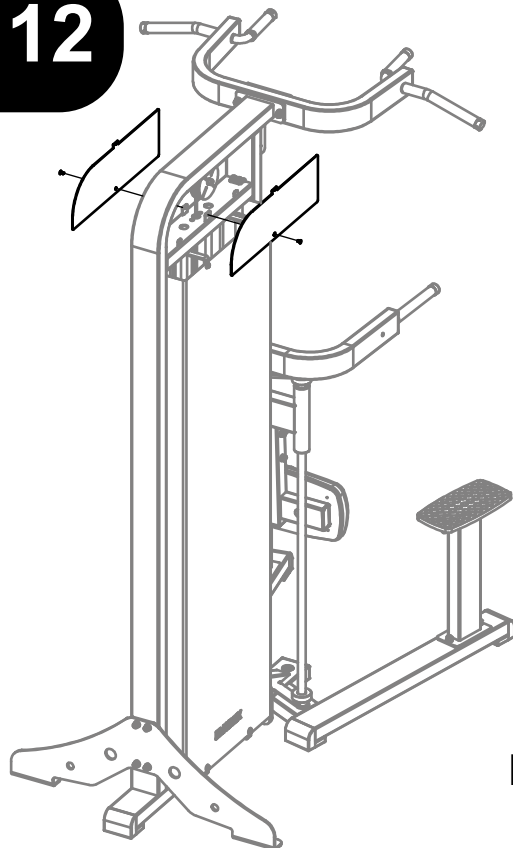

## Fixings

C5-4  
2 PCS

## Parts

Part No: 32  
Name: Logo Plate 1  
Q'TY: 1

Part No: 33  
Name: Logo Plate 2  
Q'TY: 1

## Tools

 3 mm

Install The Logo Plates.

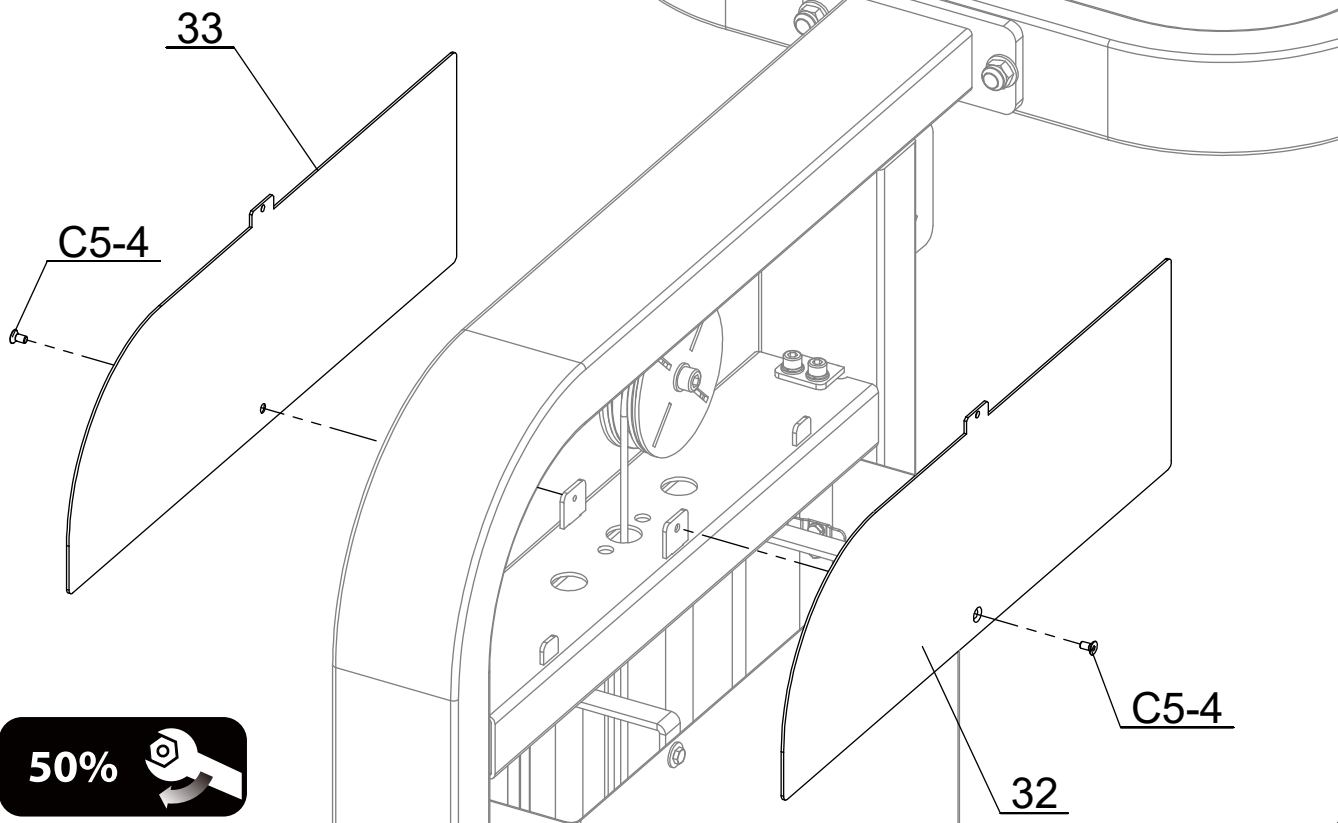

# PARTS LIST

PART#	DESCRIPTION	QTY
1	Main Frame	1
2	Bottom Frame	1
3	Brace	1
4	Shield Support	4
5	Clamp Plate	8
6	Retainer Ring	2
7	Rod Retainer	2
8	Guide Rod	2
9	Top Weight - Selector	1
10	Weight Plate	14
11	Weight Pin	1
12	Buffer Ring ID19	2
13	Fixing Plate	1
14	D24.8 Buffer Ring	2
15	Guide Rod D25	2
16	Sliding Frame	1
17	D25.5 Buffer Ring	2
18	D25 Cap	3
19	114 Pulley	2
20	Cable	1
21	Cushion Holding Frame	1
22	Shaft	1
23	Knee Cushion	1
24	Left Pedal Assy	1
25	Right Pedal Assy	1
26	Dip Arm	2
27	Handle Frame Holder	1
28	Front Left Shield Plate	1

PART#	DESCRIPTION	QTY
29	Front Right Shield Plate	1
30	Weight Label	1
31	Back Shield Plate	1
32	Logo Plate 1	1
33	Logo Plate 2	1
N10	Nut M10	10
N12	Nut M12	2
C5-4	Countersunk Head Screw M5X10	2
H6-4	Hex Head Bolt M6X10	32
S6-2	Socket Set Screw M6X6	4
S6-3	Socket Set Screw M6X8	2
S8-10	Socket Set Screw M8X50	2
SC8-6	Socket Cap Screw M8X30	2
SC10-5	Socket Cap Screw M10X25	12
SC10-6	Socket Cap Screw M10X30	5
SC10-9	Socket Cap Screw M10X45	1
SC10-10	Socket Cap Screw M10X50	1
SC10-14	Socket Cap Screw M10X70	2
SC10-23	Socket Cap Screw M10X115	1
SC10-25	Socket Cap Screw M10X125	2
SC12-16	Socket Cap Screw M12X80	2
SW10	Spring Washer $\Phi$	12
W6B	Big Washer $\Phi$	8
W6	Washer $\Phi$ 6	24
W8	Washer $\Phi$ 8	2
W10	Washer $\Phi$ 10	34
W12	Washer $\Phi$ 12	4