

BLK BOX

Plate Loaded Pendulum Squat

Setup Instructions

 CAUTION: Read all precautions and instructions before using this equipment. Save this manual for future reference.



Table Of Contents

Assembly Instructions.....2-21

Part List.....22

To Apply Thread Locker

The Fasteners marked by the sign  in the following assembling steps need to be bonded to prevent loosening, or the fasteners are a type of thread locking screws.

How to use

1. Degrease and clean surfaces prior to apply adhesive.
2. Insert bolt and apply adhesive to the exposed thread. Assemble nut and tighten to the correct torque (FIG 1).
3. Apply several drops of adhesive down the sides of the blind hole filling the lower third. Apply several drops to the bolt, Assemble and tighten (FIG 2).

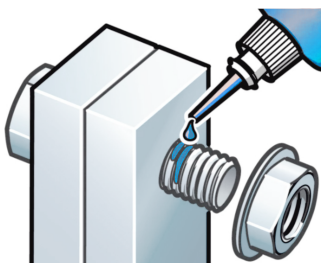

FIG 1

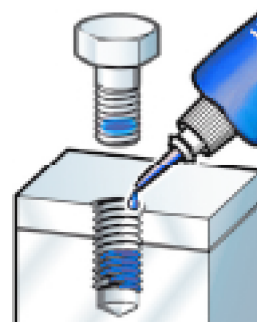

FIG 2

Fixings

SC10-26
2 PCS



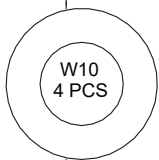

N10
2 PCS



W10
4 PCS

Parts

Part No: 1 
Name: Bottom Lengthwise Tube
Q'TY: 1

Part No: 2 
Name: Bottom Support
Q'TY: 1

Part No: 3 
Name: Backing Plate L170 W50
Q'TY: 1

Assemble the Bottom Lengthwise Tube(#1) and the Bottom Support(#2).

STEP 1

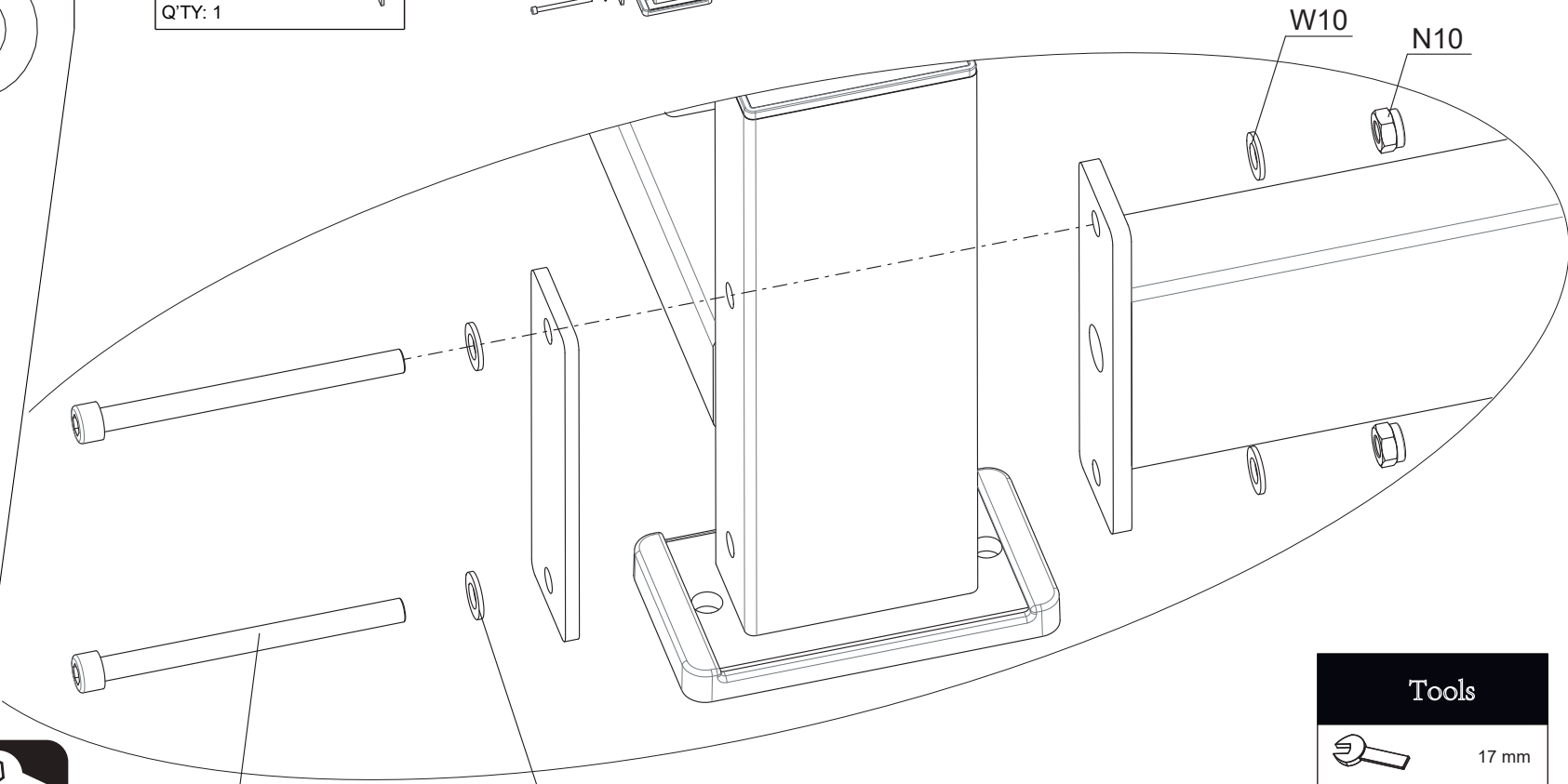
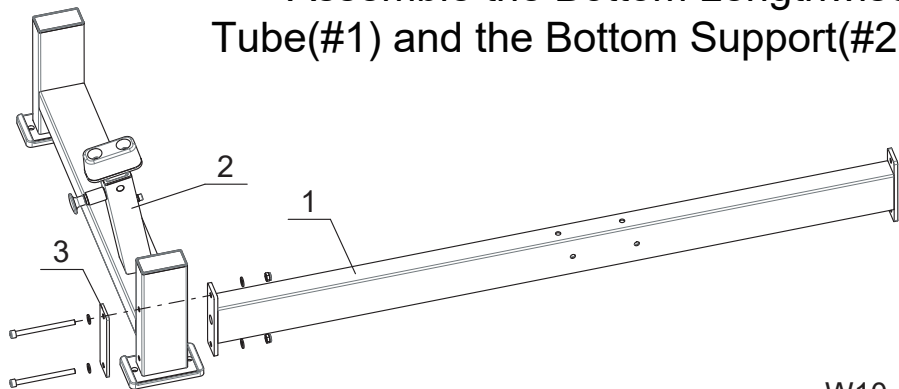

SC10-26

W10

Tools



17 mm



8 mm

Fixings

SC10-16
2 PCS

N10
2 PCS

W10
4 PCS

Parts

Part No:4
Name:
Bottom Lateral Tube
Q'TY: 1
Part No:5
Name:
Backing Plate L170 W85
Q'TY: 1

Tools

17 mm
8 mm

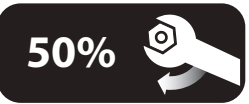
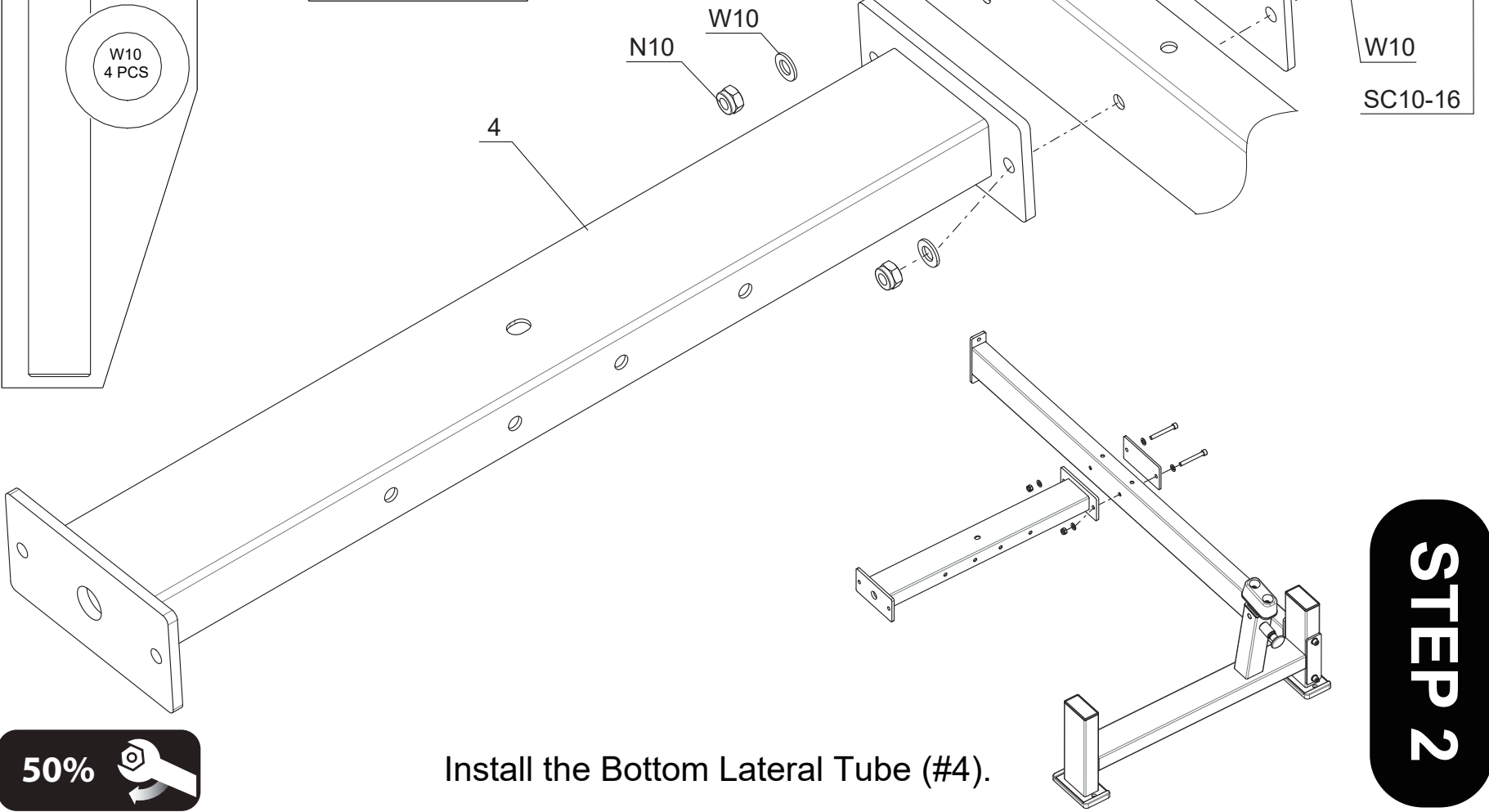
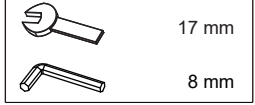
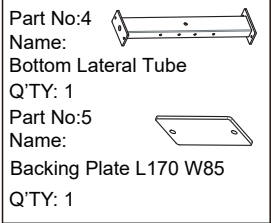
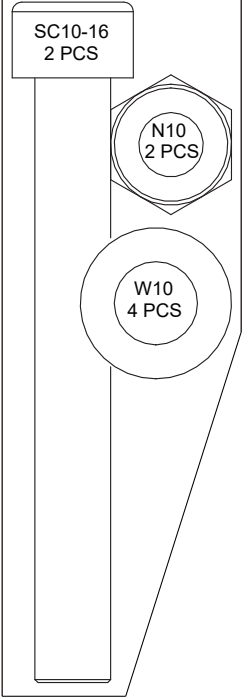

Install the Bottom Lateral Tube (#4).

STEP 2

Fixings

SC10-16
2 PCS

N10
2 PCS

W10
4 PCS

Tools



17 mm



8 mm

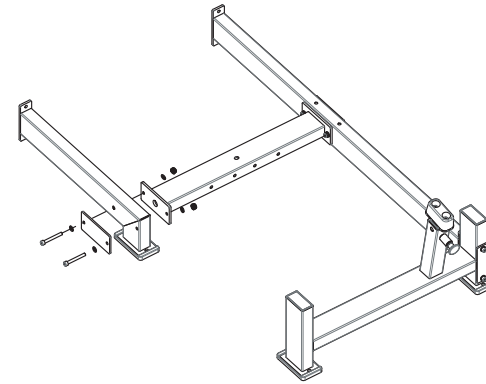

STEP 3

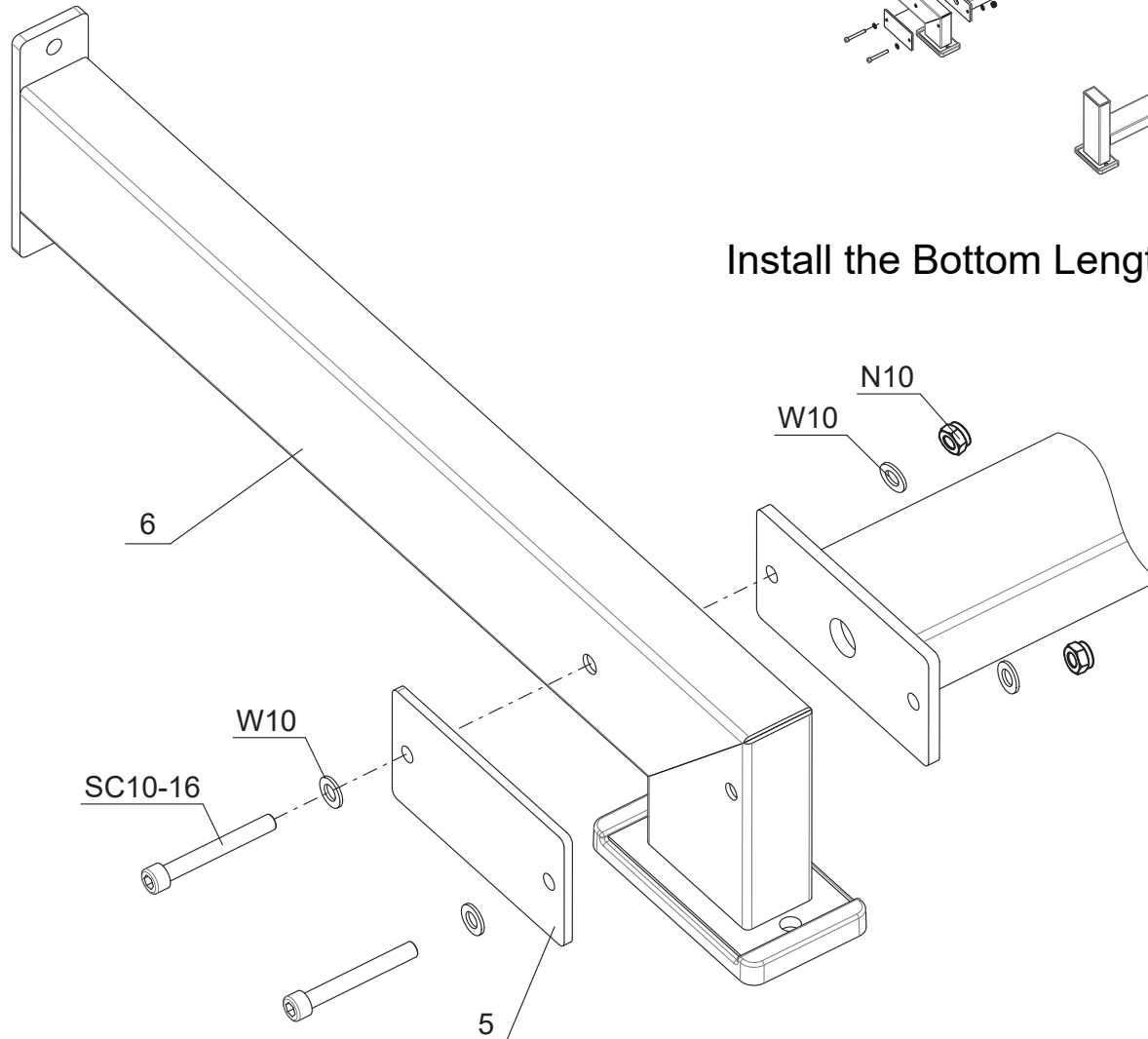

Install the Bottom Lengthwise Tube (#6).



Parts

- Part No: 6 
Name: Bottom Lengthwise Tube
Q'TY: 1
- Part No: 5 
Name: Backing Plate L170 W85
Q'TY: 1

50%



Install the Rear Upright (#7).

STEP 4

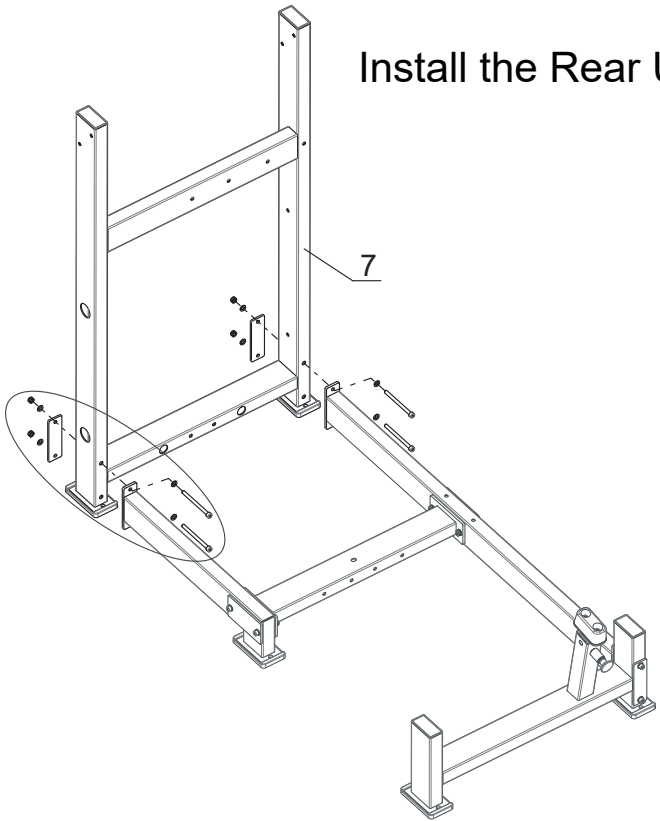

Parts	
Part No: 7 Name: Rear Upright Q'TY: 1	
Part No: 3 Name: Backing Plate L170 W50 Q'TY: 2	

Fixings	
	SC10-26 4 PCS
	N10 4 PCS
	W10 8 PCS

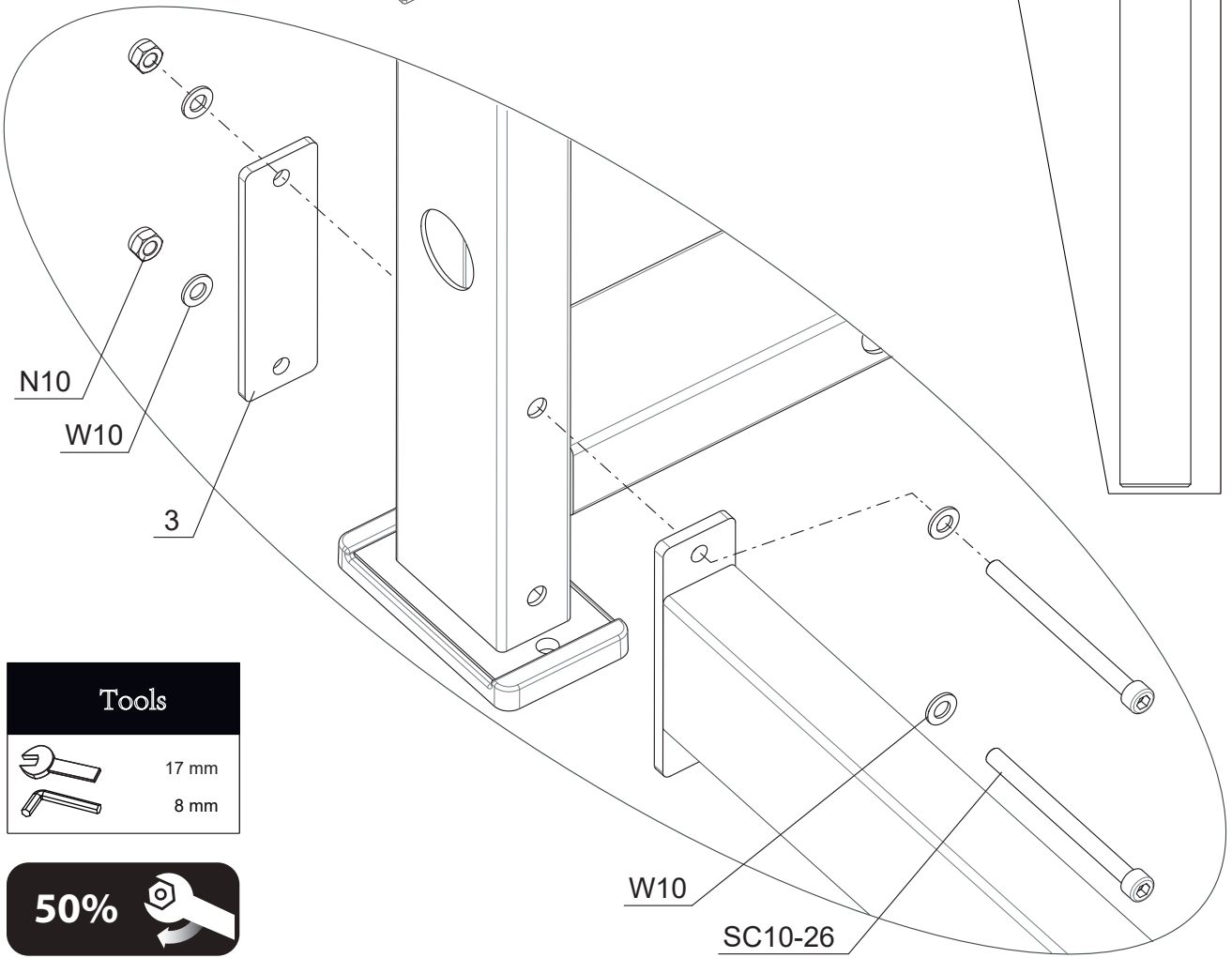

Tools	
	17 mm
	8 mm



STEP 5

Install the Adjusting Tube (#8).

Parts

Part No: 8
Name: Adjusting Tube
Q'TY: 1



Fixings

SC10-25
4 PCS

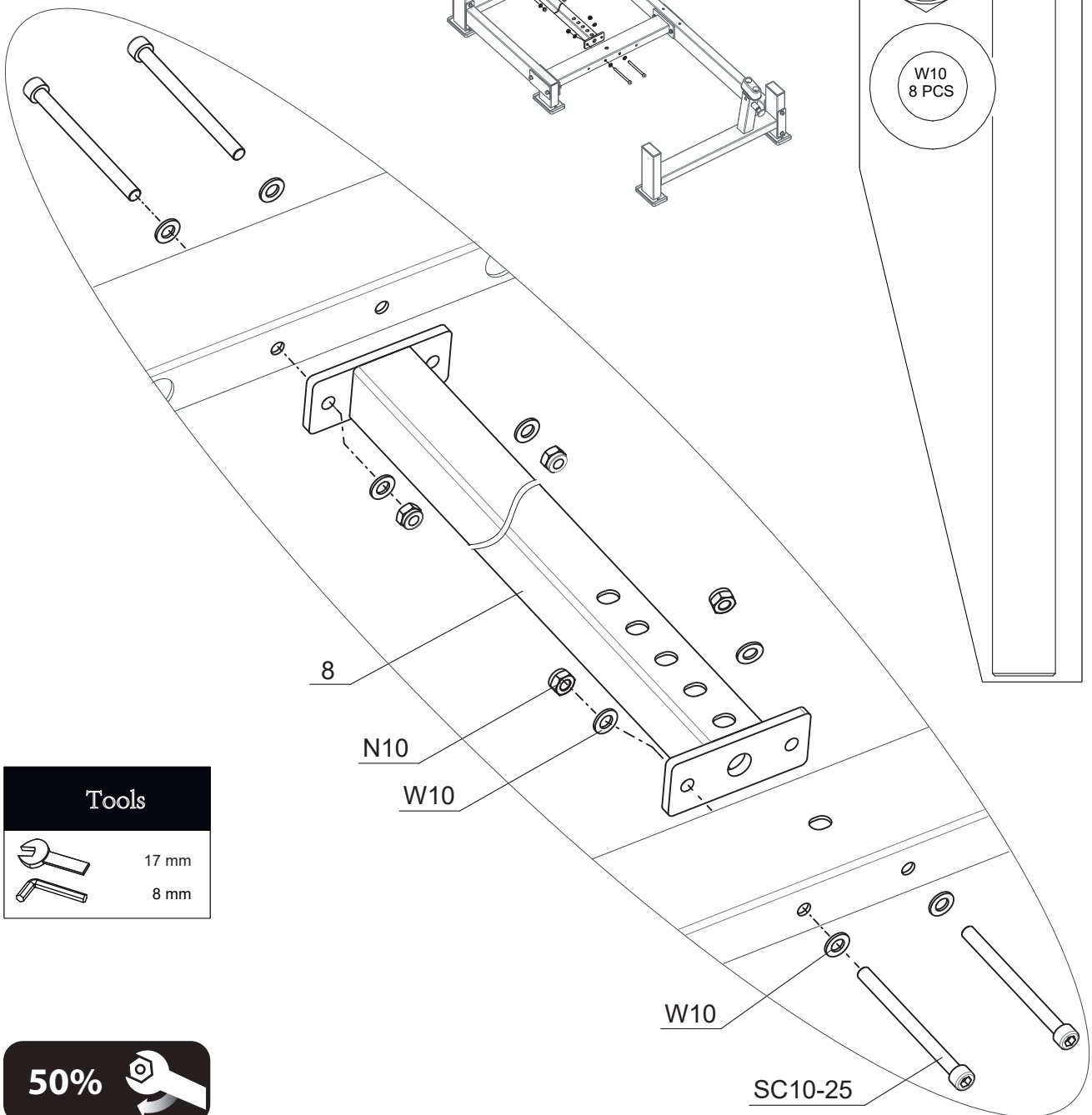
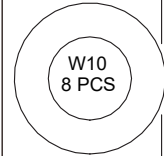

Tools



17 mm

8 mm

50%



Tools

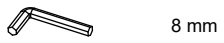

8 mm

Parts

Part No: 9
Name: Carriage
Q'TY: 1



Part No: 10
Name: Guide Rod
Q'TY: 2

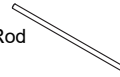

Part No: 11
Name: Buffer
Q'TY: 4



Fixings

SC10-4
4 PCS

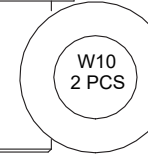

W10
2 PCS

Parts

W10B
2 PCS

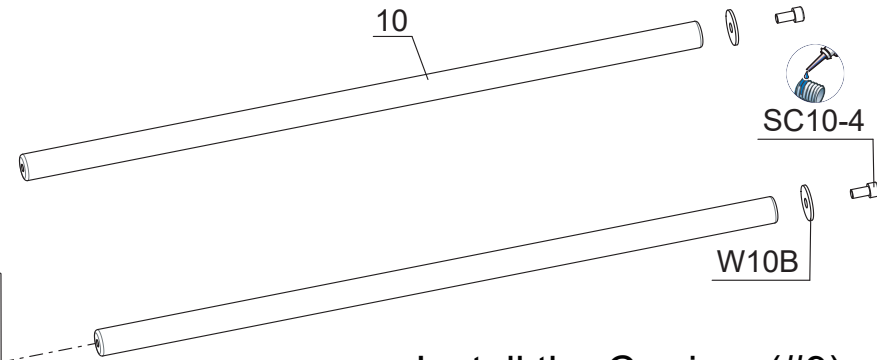
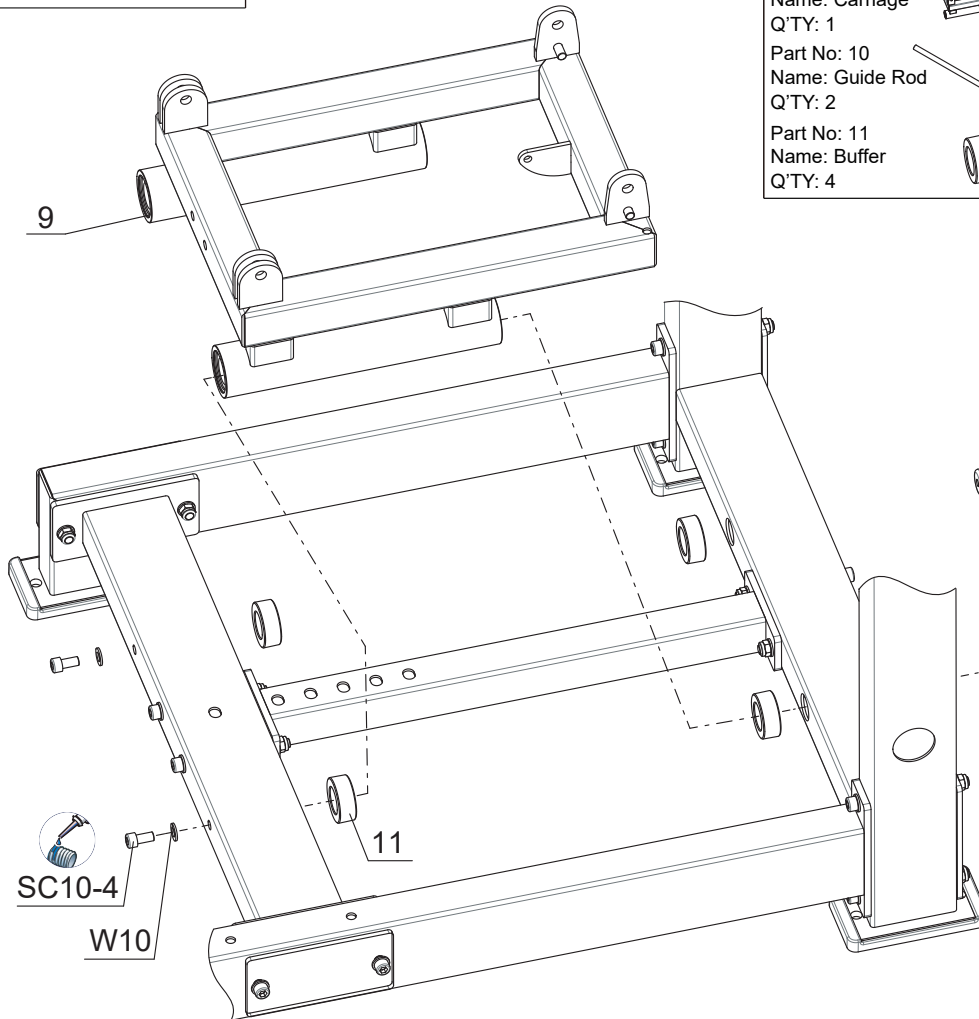
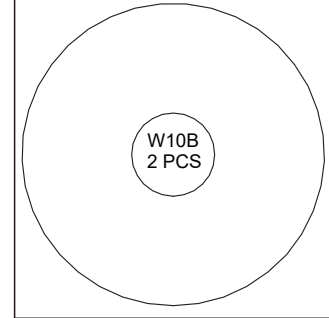

Install the Carriage(#9).

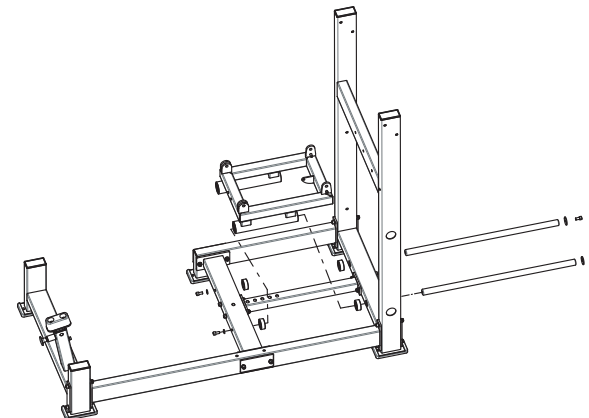

STEP 6

50%



STEP 7

Install the
Positioning Plate (#12).

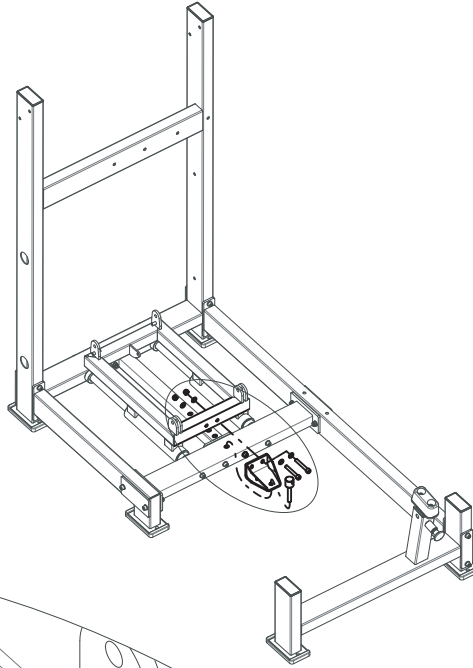

Fixings

SC10-14
2 PCS

W10
4 PCS

N10
2 PCS

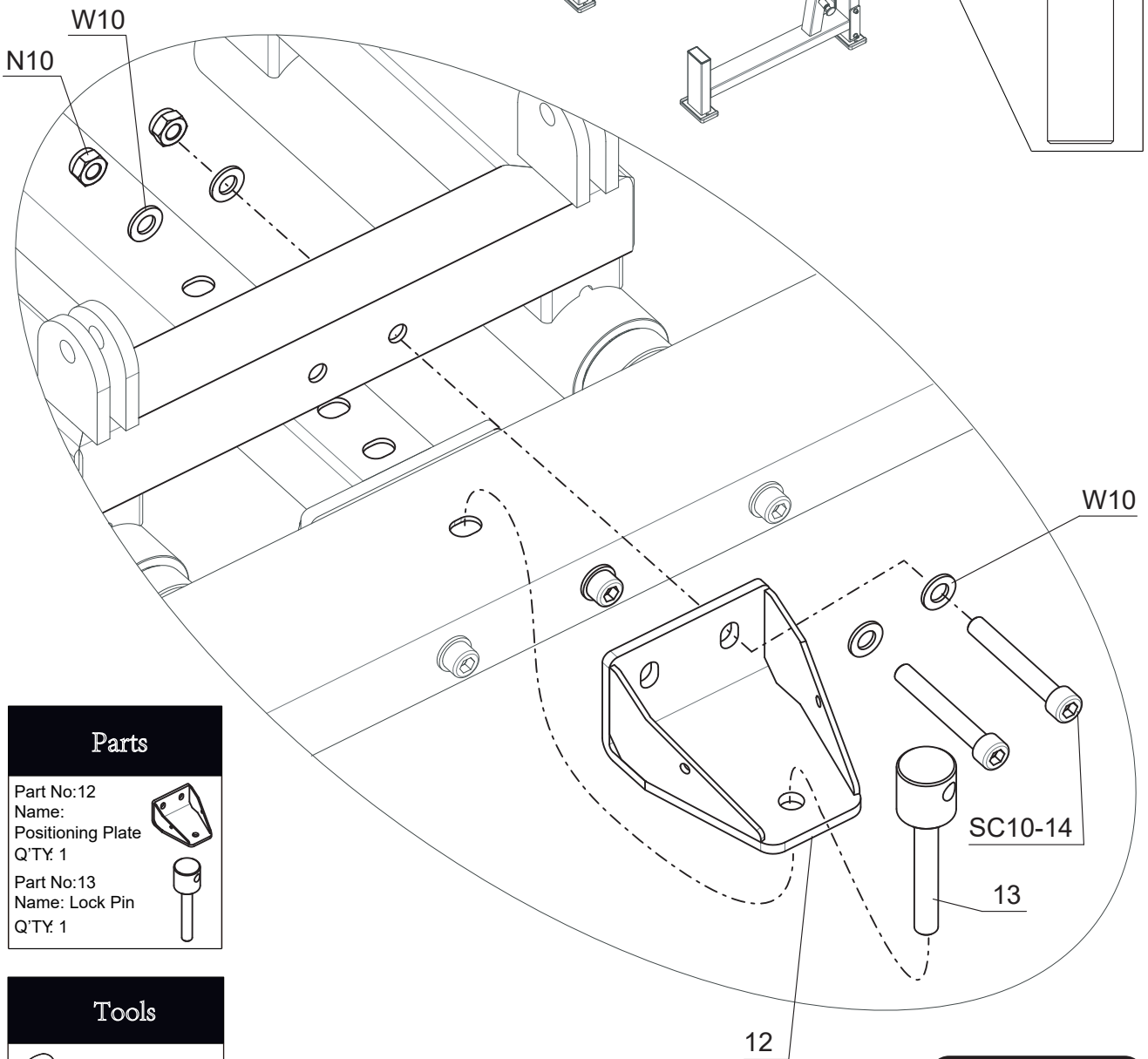

Parts

Part No:12
Name:
Positioning Plate
Q'TY: 1



Part No:13
Name: Lock Pin
Q'TY: 1



Tools



17 mm



8 mm

50%



Fixings

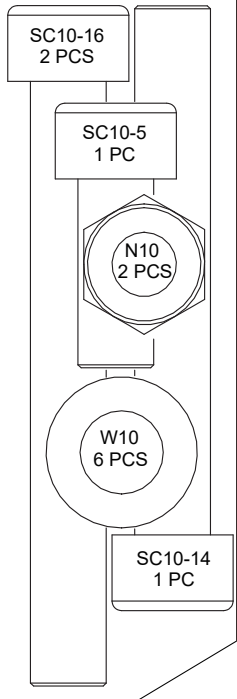

Tools



Parts

Part No: 14
Name: Connecting Frame
Q'TY: 1

Part No: 15
Name: Backing Plate L330 W90
Q'TY: 1

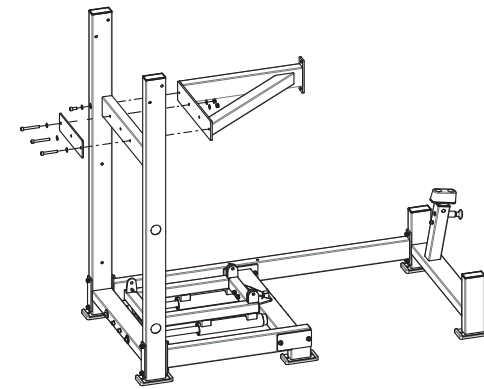

Install the Connecting Frame (#14).

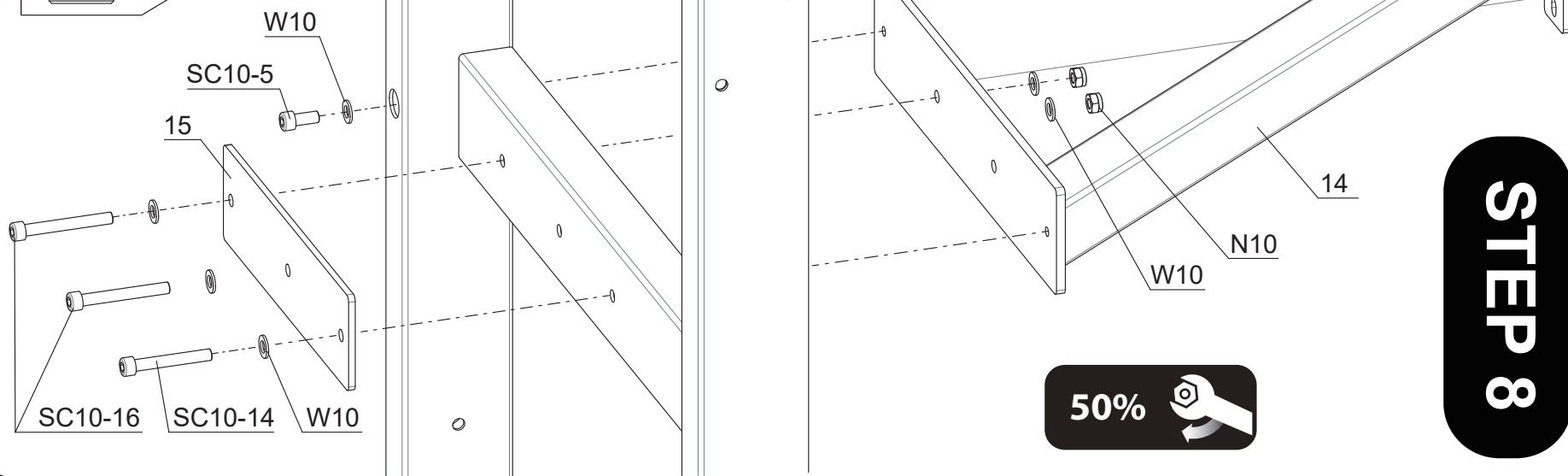

50%

STEP 8

STEP 9

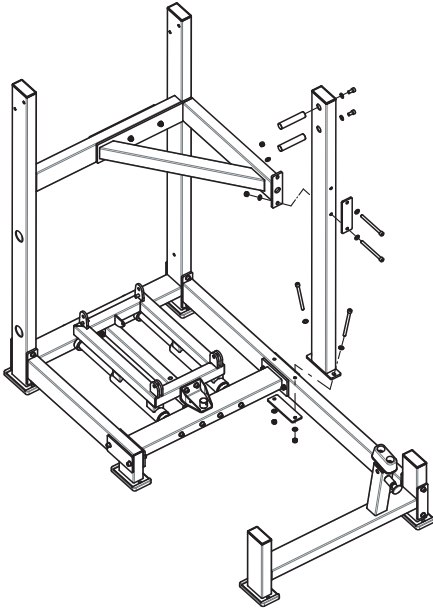

Install the Middle Upright (#16).

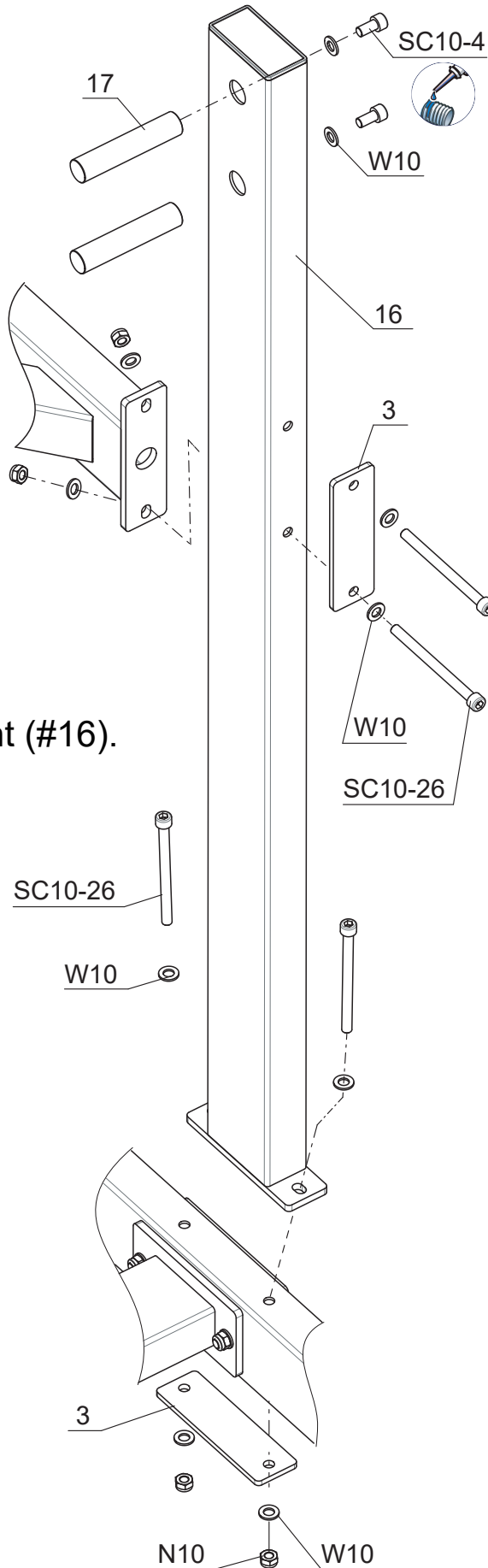

Fixings	
	SC10-26 4 PCS
	SC10-4 2 PCS
	N10 4 PCS
	W10 10 PCS

Parts	
Part No:16 Name: Middle Upright Q'TY: 1	
Part No:17 Name: Peg Q'TY: 2	
Part No: 3 Name: Backing Plate Q'TY: 2	



Tools	
	17 mm
	8 mm

Fixings

SC10-5
4 PCS

W10
4 PCS

Install the Storage Bar (#18).

STEP 10

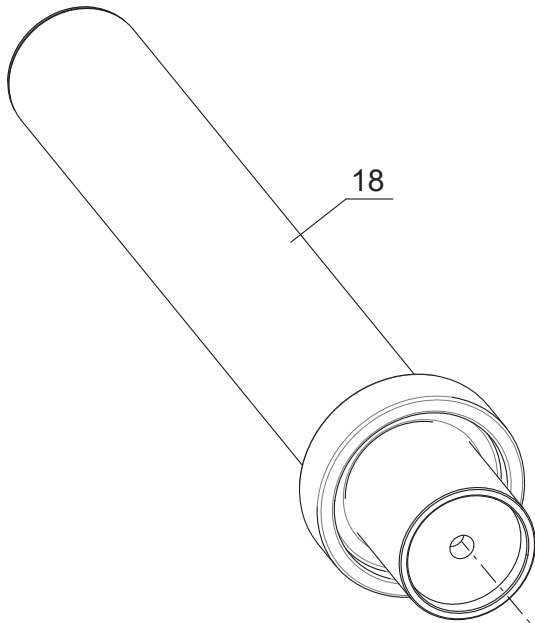
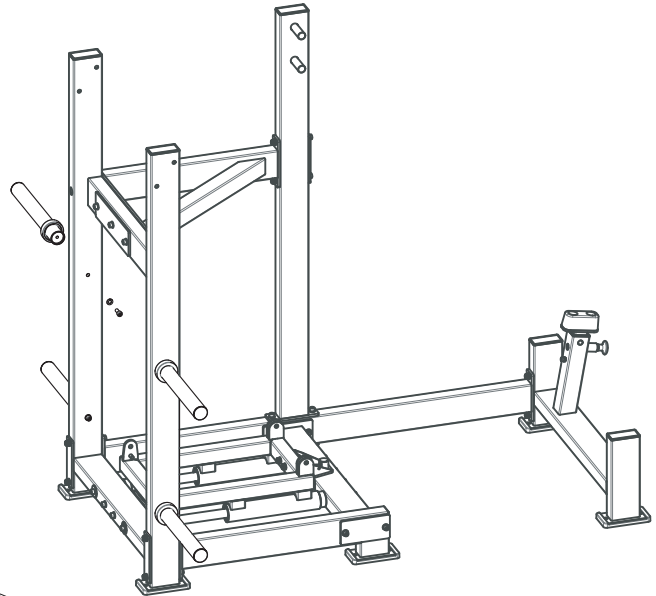

18

Parts

Part No: 18
Name: Storage Bar
Q'TY: 4

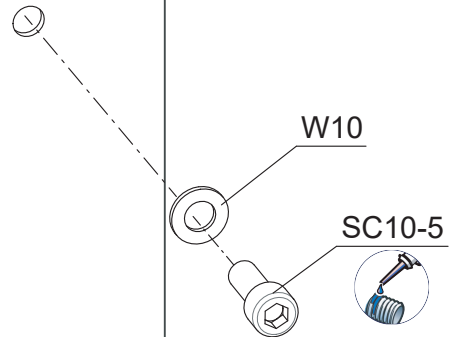

W10

SC10-5



Tools



8 mm

50%



STEP 11

Install the Pedal (#19).

Parts

Part No: 19
Name: Pedal
QTY: 1



Part No: 20
Name: Shoulder Bolt 12x30
QTY: 2



Tools



17 mm

6 mm

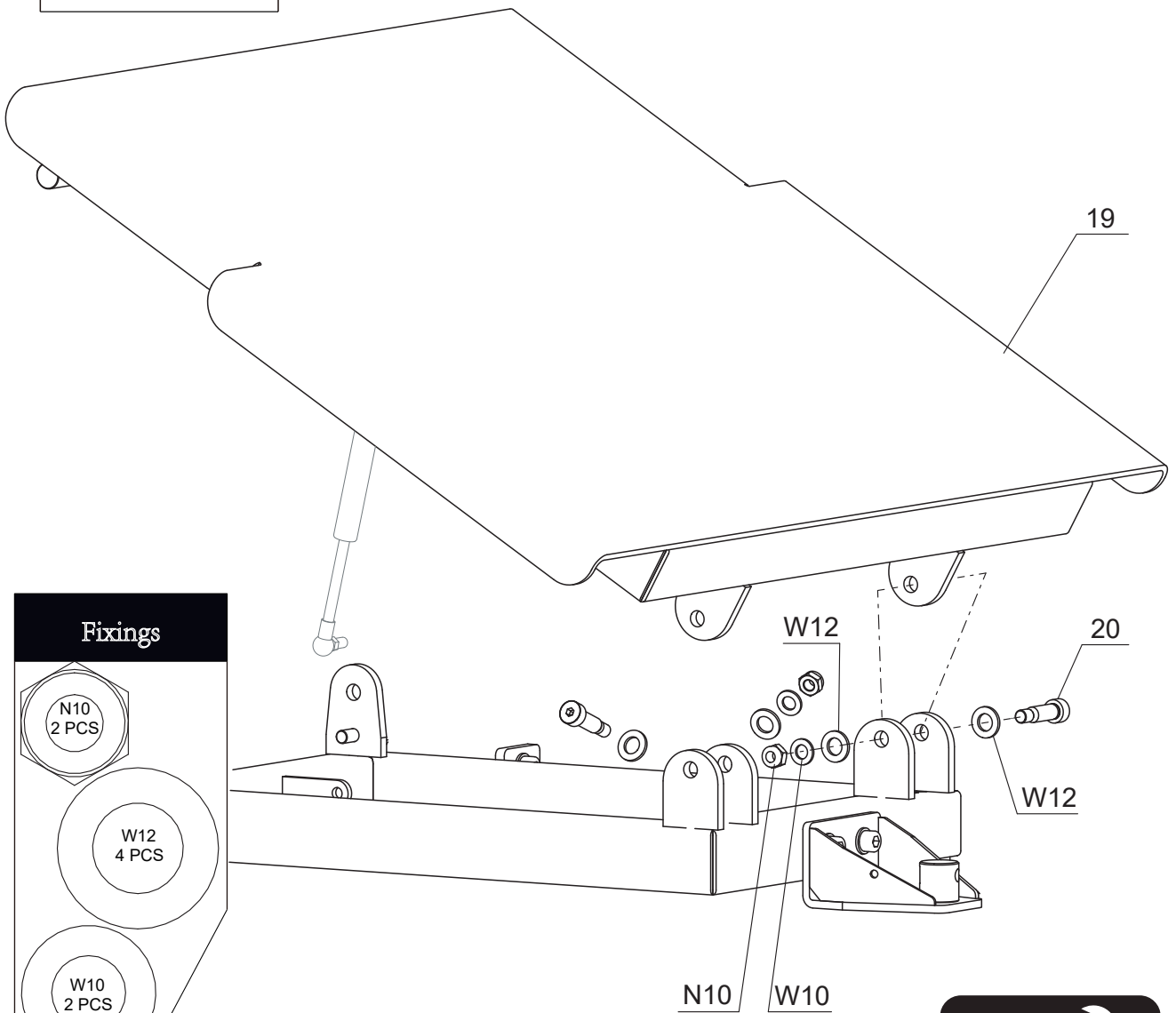
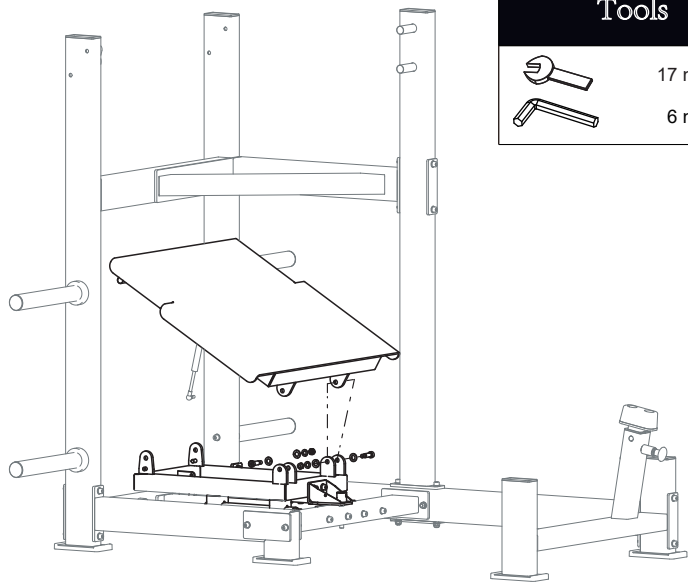

Fixings

N10
2 PCS

W12
4 PCS

W10
2 PCS

N10

W10

W12

20

W12

50%



STEP 12

Fix the Gas Spring(#21).

Fixings

W8 2 PCS	N8 2 PCS
-------------	-------------

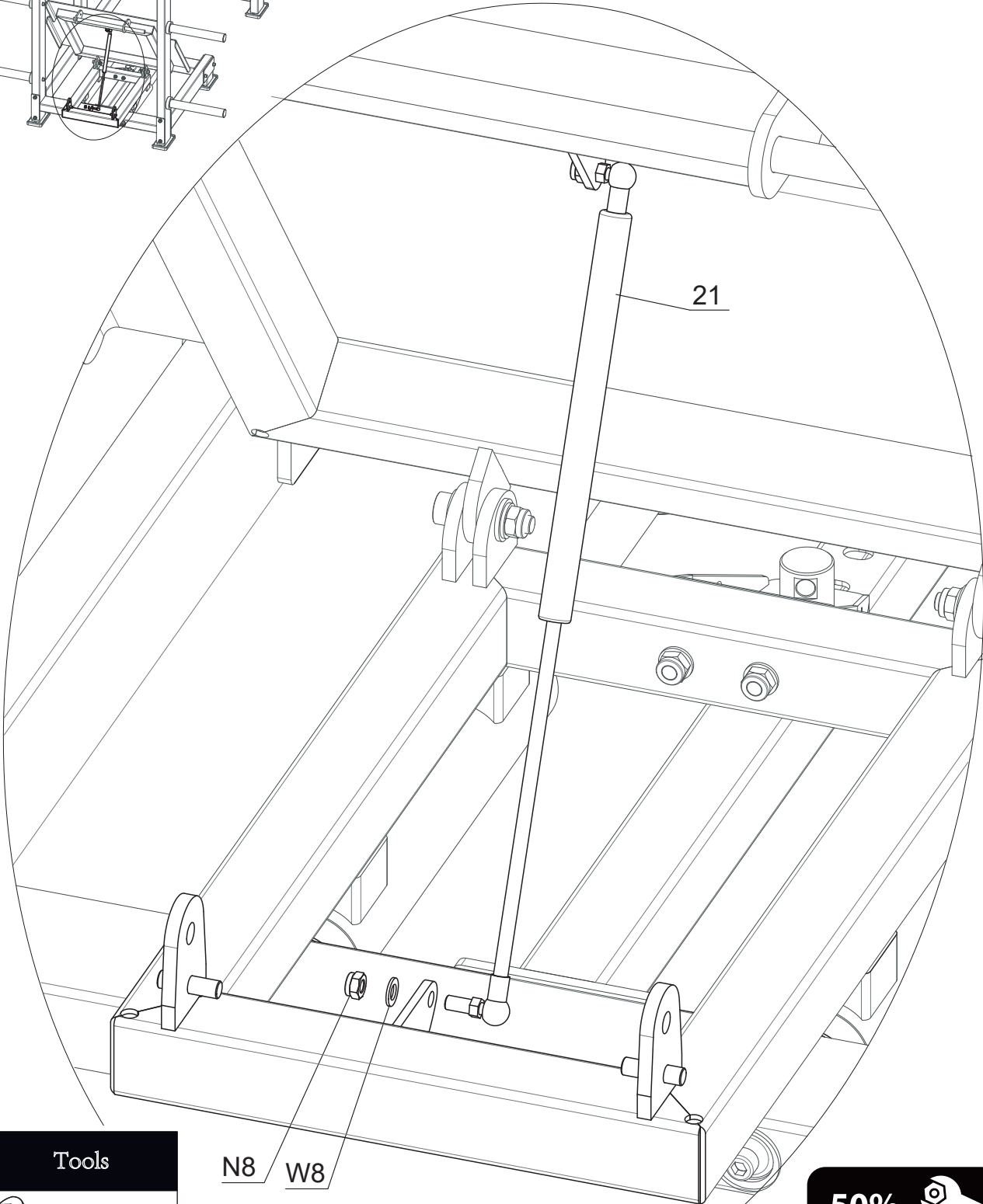
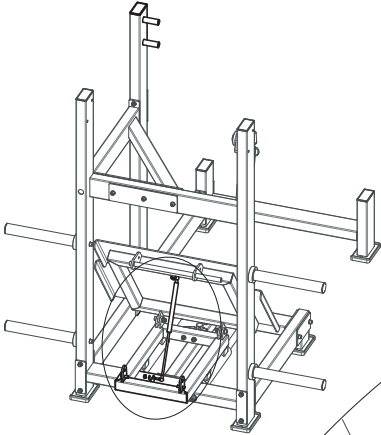

Tools

14 mm

N8 W8

50%

STEP 13

Install the Brace (#22).

Fixings

SC12-6
2 PCS

W12
2 PCS

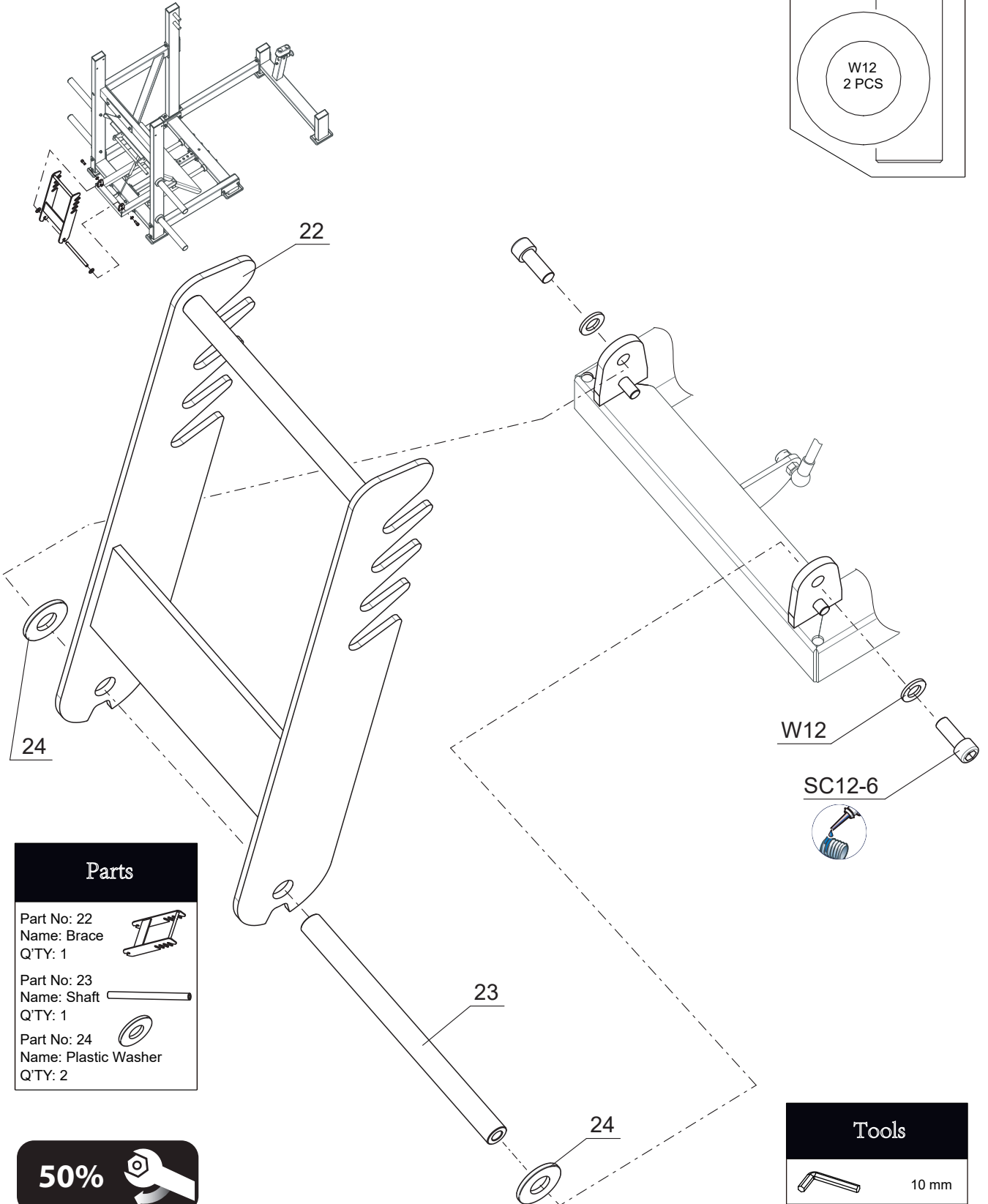

Parts

Part No: 22
Name: Brace
Q'TY: 1



Part No: 23
Name: Shaft
Q'TY: 1



Part No: 24
Name: Plastic Washer
Q'TY: 2



50%



Tools



10 mm

STEP 14

Install the Hook(#26) and Handle(#25) onto the work Arm(#27).

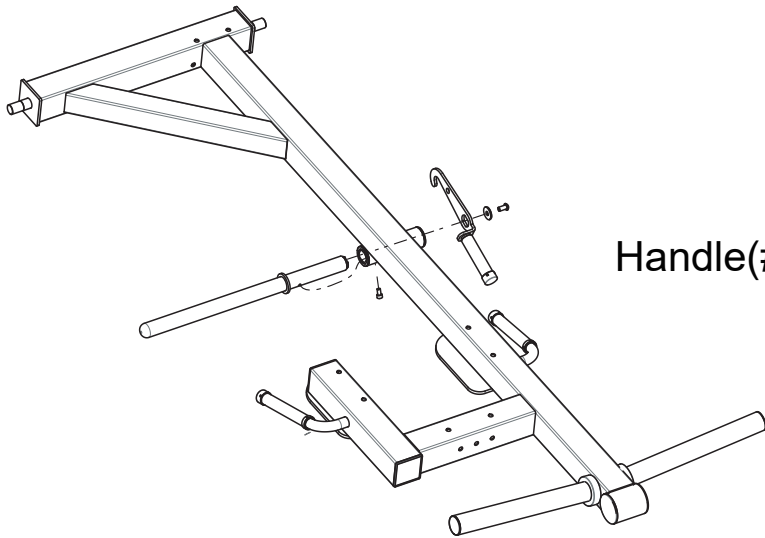

Fixings

- SC8-3
1 PC
- A10-4
1 PC
- W10C
1 PC

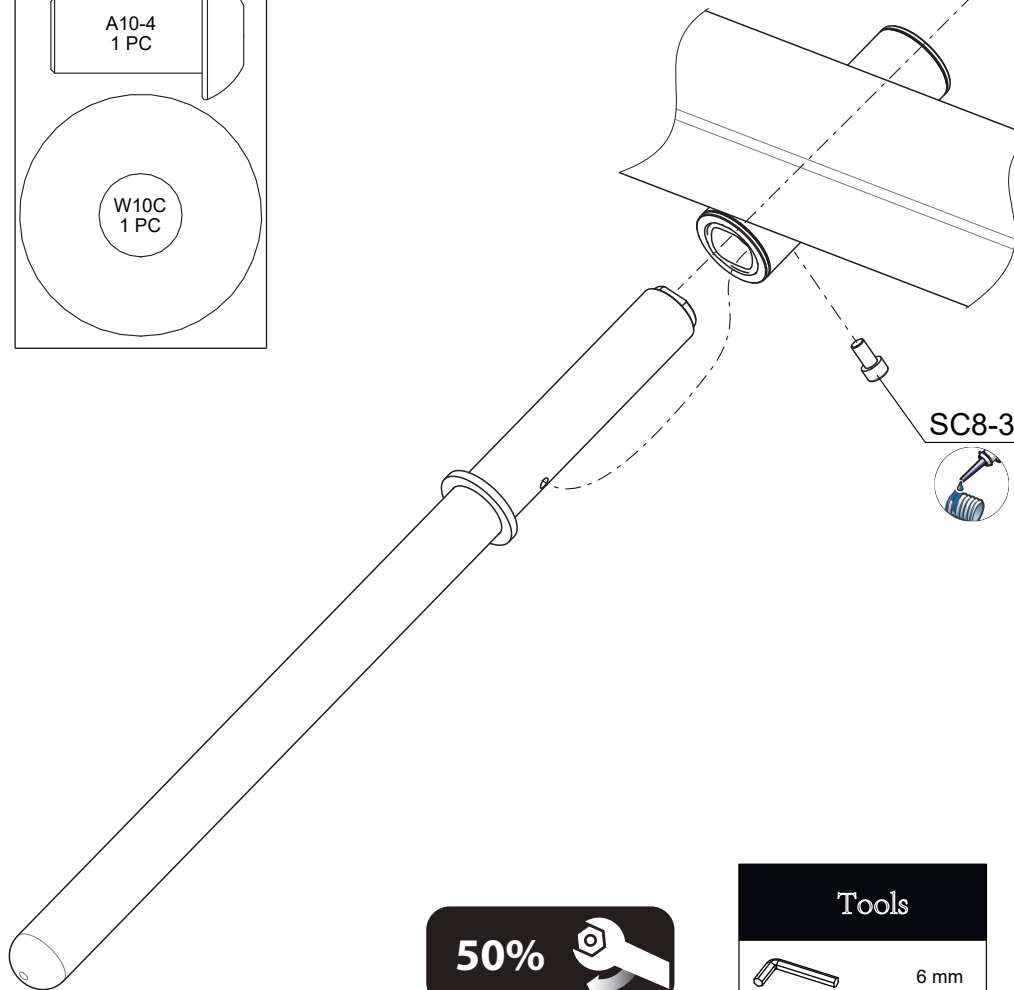
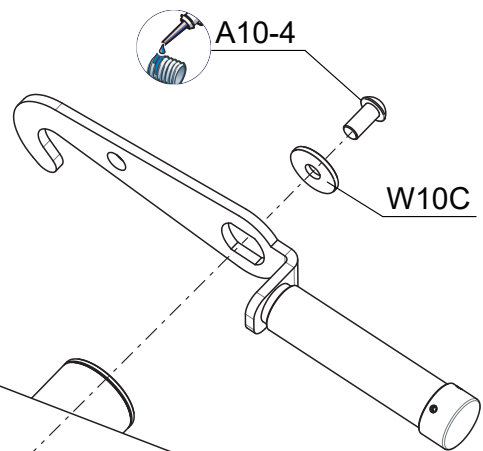

Parts

- Part No: 25
Name: Handle
Q'TY: 1
- Part No: 26
Name: Hook
Q'TY: 1
- Part No: 27
Name: Work Arm
Q'TY: 1

Tools

- 6 mm

50%

STEP 15

Install the Mounted Bearing (#28) and Barbell Collar(#29) onto the Work Arm(#27).

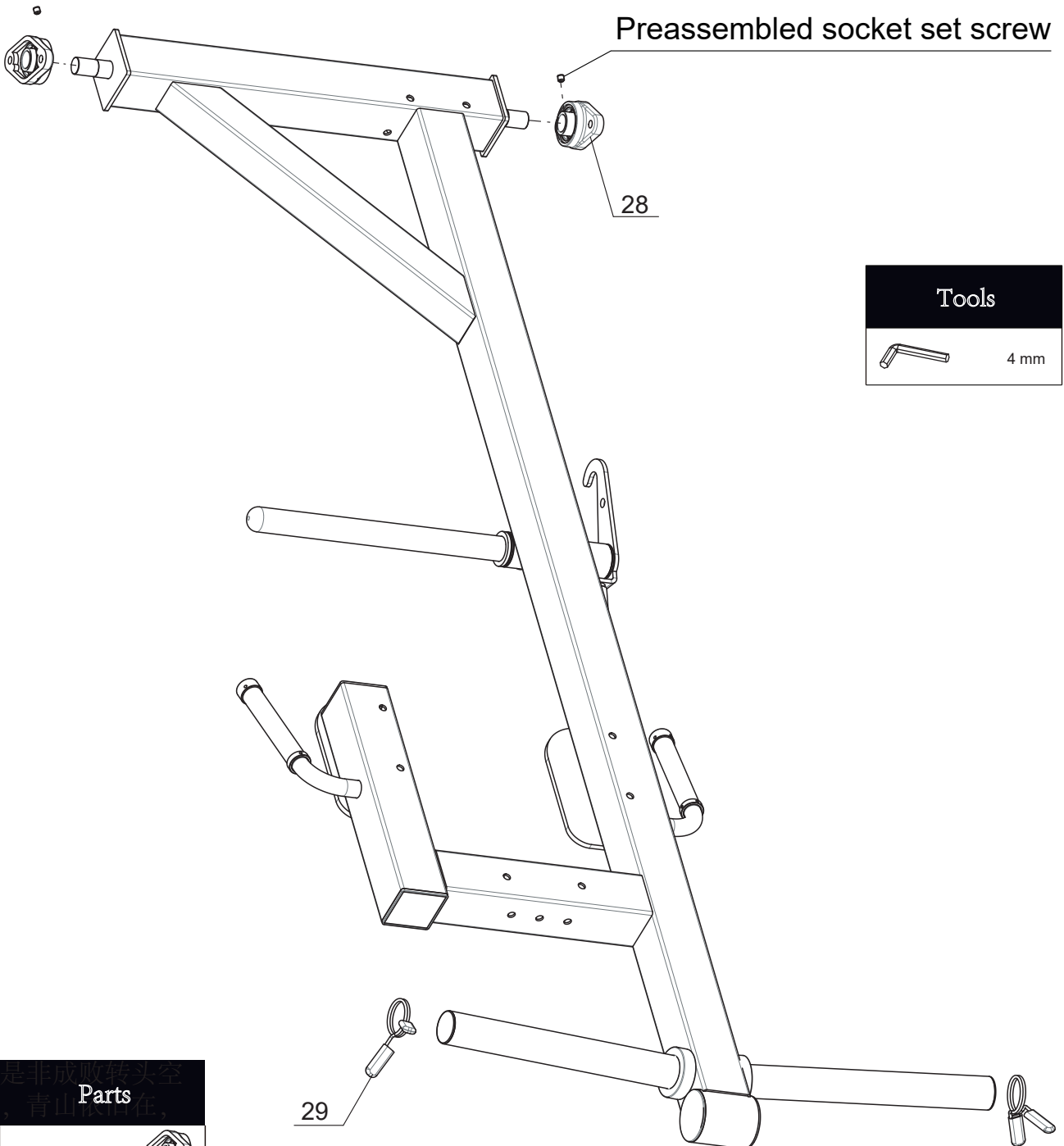

Preassembled socket set screw

28

29

Tools



4 mm

Parts

Part No: 28
Name: Mounted Bearing
Q'TY: 2
Part No: 29
Name: Barbell Collar
Q'TY: 2



50%



Tools

- 17 mm
- 8 mm

Install the Work Arm(#27).

STEP 16

Parts

- Part No: 27
Name: Work Arm
QTY: 1
- Part No: 30
Name: Backing Plate L125 W90
QTY: 2

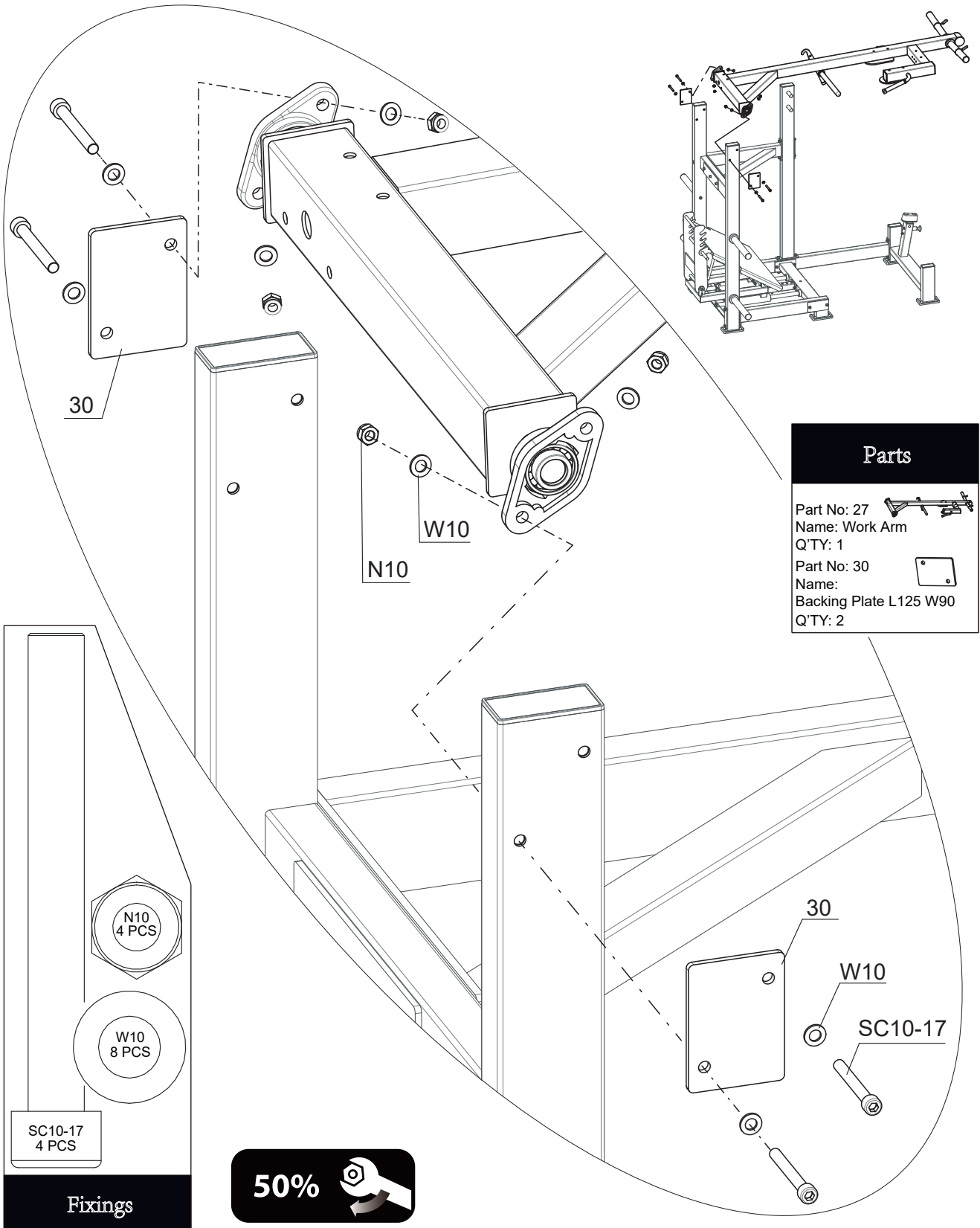

- N10
4 PCS
- W10
8 PCS

SC10-17
4 PCS

Fixings



STEP 17

Install the Counter Weight Group(#31).

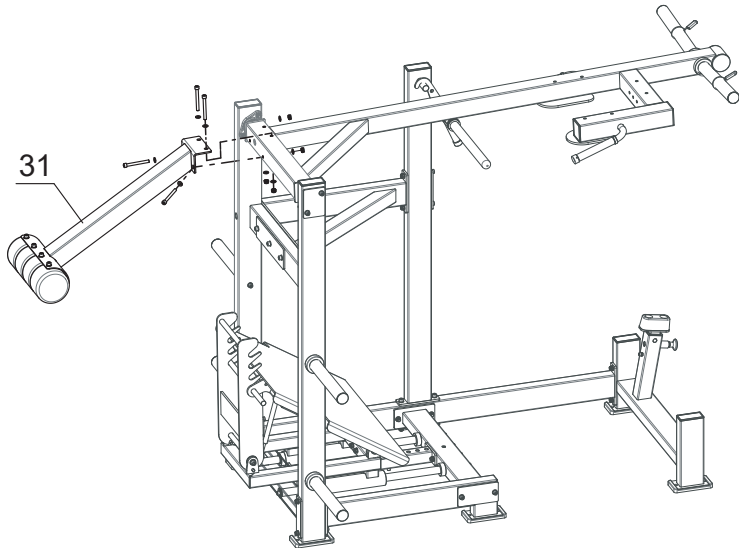

Fixings

SC10-19
4 PCS

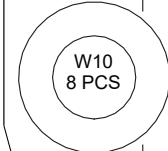

Parts

Part No: 31
Name:
Counter Weight Group
QTY: 1

SC10-19

W10

W10

SC10-19

W10

N10

Tools



17 mm



8 mm

50%



STEP 18

Install the Backrest Pad Support(#32).

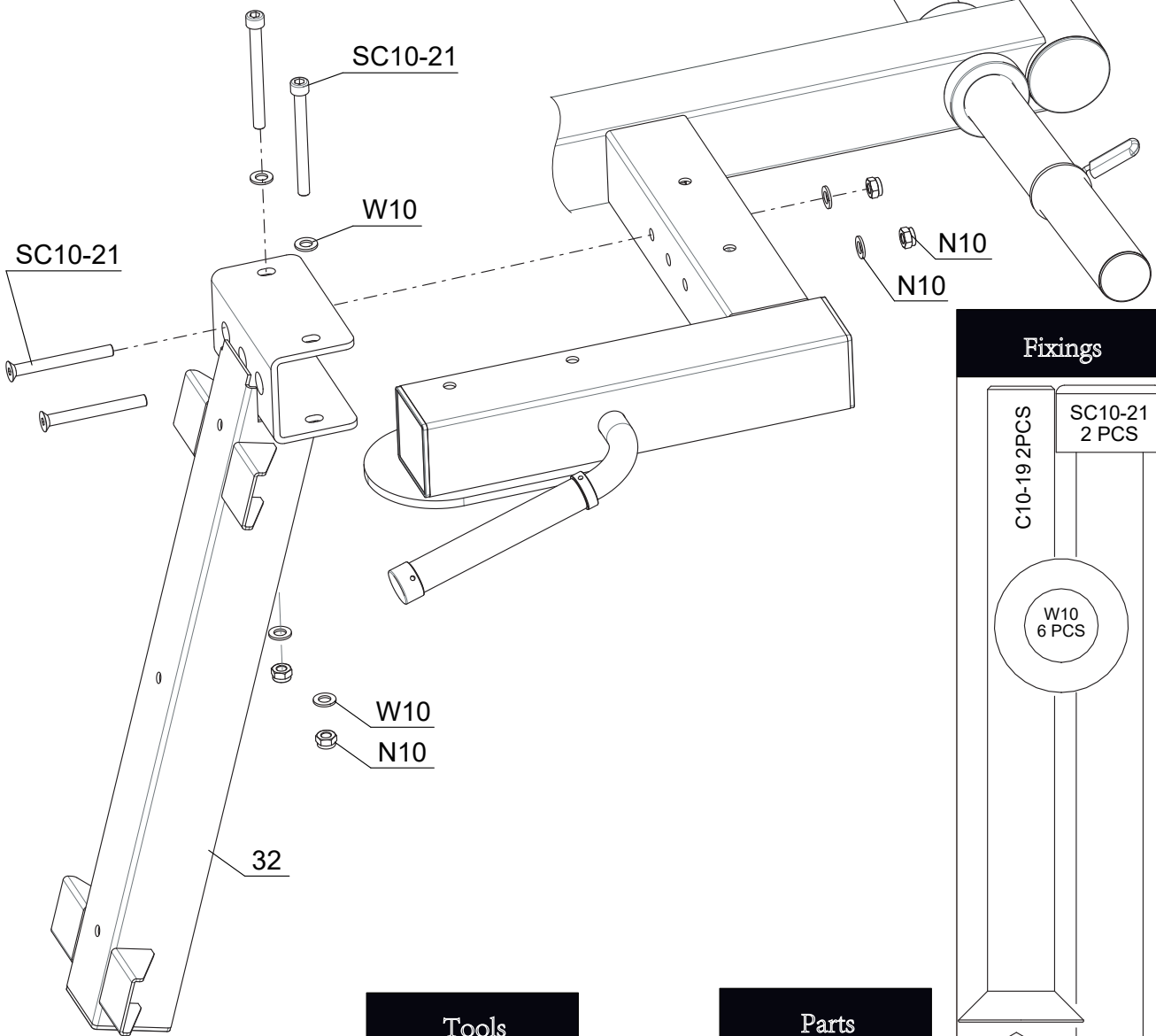
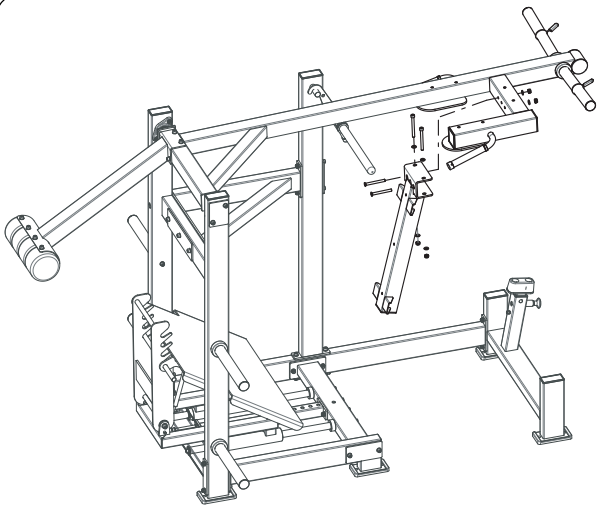

Fixings

C10-19 2PCS

SC10-21
2 PCS

W10
6 PCS

N10
4 PCS

Tools

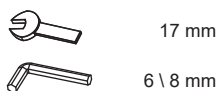

Parts

Part No:32
Name:
Backrest Pad Support
Q'TY: 1

100%



STEP 19

Install the Shoulder Pad(#33) and the Backrest Pad(#34).

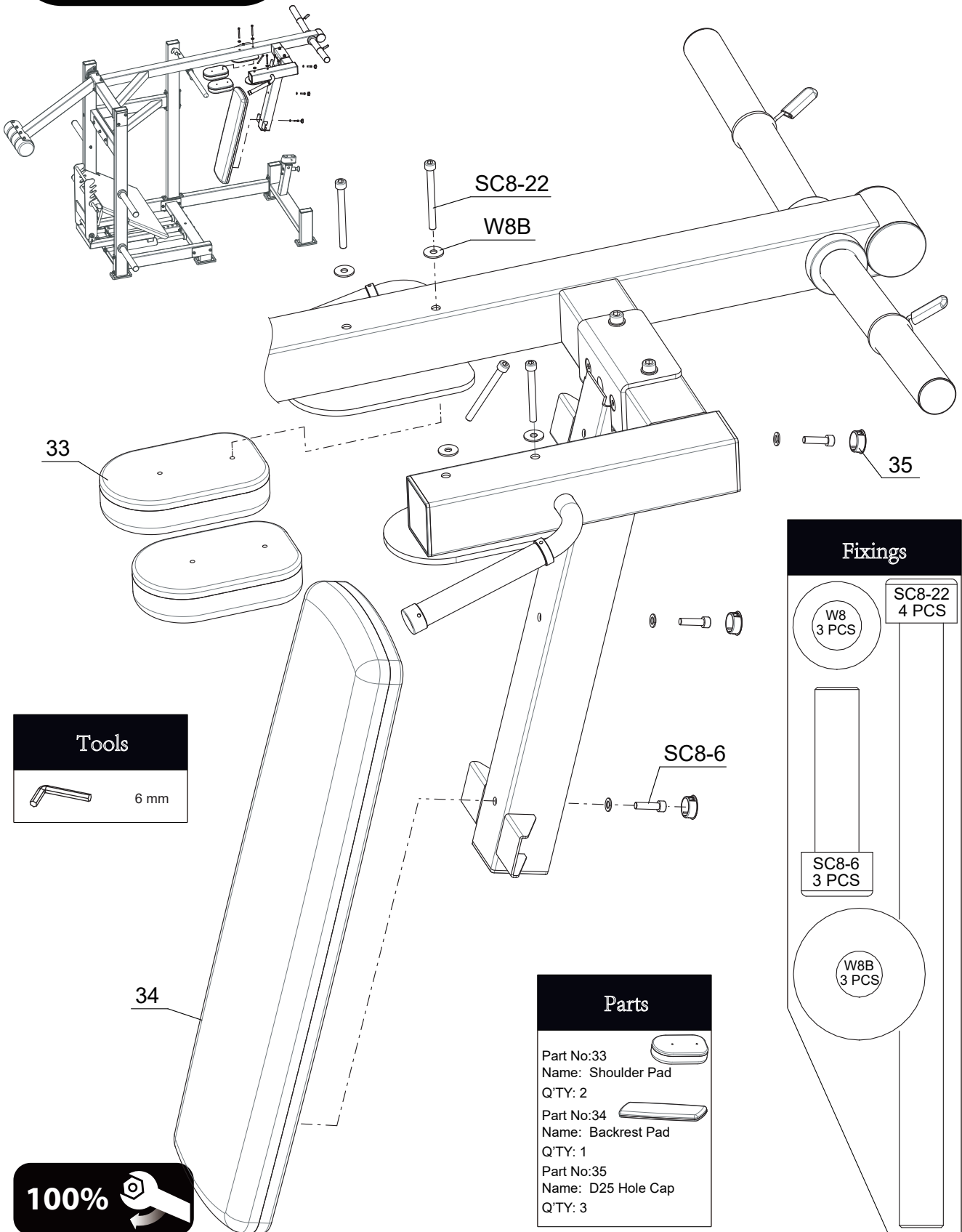

Fixings

W8 3 PCS	SC8-22 4 PCS
SC8-6 3 PCS	
W8B 3 PCS	

Parts

- Part No:33
Name: Shoulder Pad
Q'TY: 2
- Part No:34
Name: Backrest Pad
Q'TY: 1
- Part No:35
Name: D25 Hole Cap
Q'TY: 3

100%



PARTS LIST

PART#	DESCRIPTION	Qty
1	Bottom Lengthwise Tube	1
2	Bottom Support	1
3	Backing Plate L170 W50	5
4	Bottom Lateral Tube	1
5	Backing Plate L170 W85	2
6	Bottom Lengthwise Tube	1
7	Rear Upright	1
8	Adjusting Tube	1
9	Carriage	1
10	Guide Rod	2
11	Buffer	4
12	Positioning Plate	1
13	Lock Pin	1
14	Connecting Frame	1
15	Backing Plate L330 W90	1
16	Middle Upright	1
17	Peg	2
18	Storage Bar	4
19	Pedal	1
20	Shoulder Bolt 12×30	2
21	Gas Spring	1
22	Brace	1
23	Shaft	1
24	Plastic Washer	2
25	Handle	1
26	Hook	1
27	Work Arm	1
28	Mounted Bearing	2
29	Barbell Collar	2
30	Backing Plate L125 W90	2

PART#	DESCRIPTION	Qty
31	Counter Weight Group	1
32	Backrest Pad Support	1
33	Shoulder Pad	2
34	Backrest Pad	1
35	D25 Hole Cap	3
A10-4	Button Head Screw M10×20	1
C10-19	Countersunk Head Screw M10×95	2
N8	Lock Nut M8	2
N10	Lock Nut M10	36
SC8-3	Socket Head Cap Screw M8×16	1
SC8-6	Socket Head Cap Screw M8×30	3
SC8-22	Socket Head Cap Screw M8×110	4
SC10-4	Socket Head Cap Screw M10×20	6
SC10-5	Socket Head Cap Screw M10×25	5
SC10-14	Socket Head Cap Screw M10×70	3
SC10-16	Socket Head Cap Screw M10×80	6
SC10-17	Socket Head Cap Screw M10×85	4
SC10-19	Socket Head Cap Screw M10×95	4
SC10-21	Socket Head Cap Screw M10×105	2
SC10-25	Socket Head Cap Screw M10×125	4
SC10-26	Socket Head Cap Screw M10×130	10
SC12-6	Socket Head Cap Screw M12×30	2
W8	Plain Washer 8	5
W8B	Big Washer ID 8.4 OD24	4
W10	Plain Washer 10	78
W10B	Plain Washer ID11 OD40	2
W10C	Plain Washer ID11 OD32	1
W12	Plain Washer 12	6