

BLK BOX

Plate Loaded Leverage Calf

Setup Instructions

 CAUTION: Read all precautions and instructions before using this equipment. Save this manual for future reference.



Table Of Contents

Assembly Instructions.....2-15

Part List..... 16

To Apply Thread Locker

The Fasteners marked by the sign  in the following assembling steps need to be bonded to prevent loosening, or the fasteners are a type of thread locking screws.

How to use

1. Degrease and clean surfaces prior to apply adhesive.
2. Insert bolt and apply adhesive to the exposed thread. Assemble nut and tighten to the correct torque (FIG 1).
3. Apply several drops of adhesive down the sides of the blind hole filling the lower third. Apply several drops to the bolt, Assemble and tighten (FIG 2).

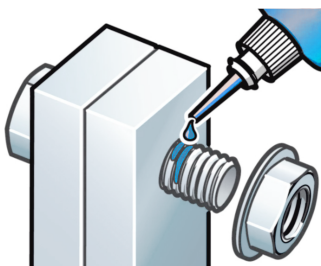

FIG 1

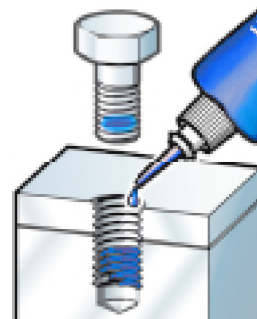
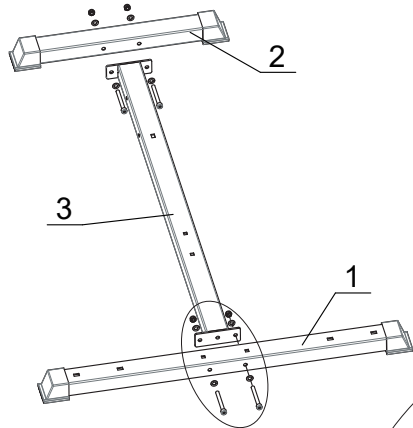

FIG 2

STEP 1

Assemble the Bottom Lateral Tube (#1 & #2) and the Lengthwise Tube(#3).



Fixings





S10-18
4 PCS

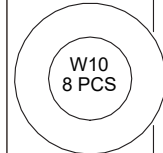

W10
8 PCS



Parts

- Part No: 1
Name: 
Bottom Lateral Tube
Q'TY: 1
- Part No: 2
Name: 
Bottom Lateral Tube
Q'TY: 1
- Part No: 
Name: 
Bottom Lengthwise Tube
Q'TY: 1

Tools

-  8 mm
-  17 mm

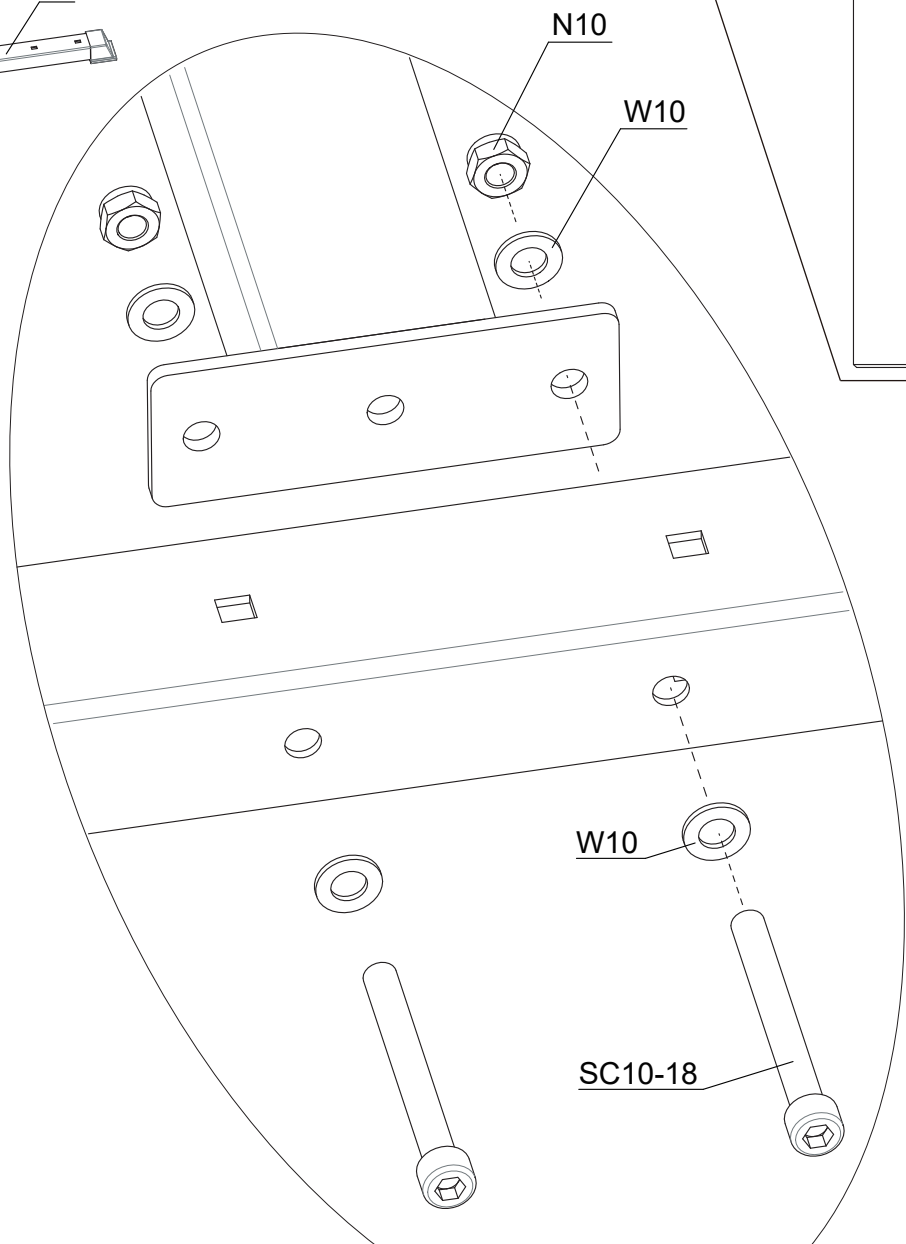

50%



Fixings



Install the Upright Support (#4).

STEP 2

N10

W10

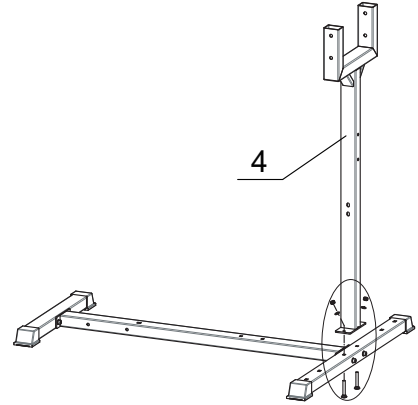
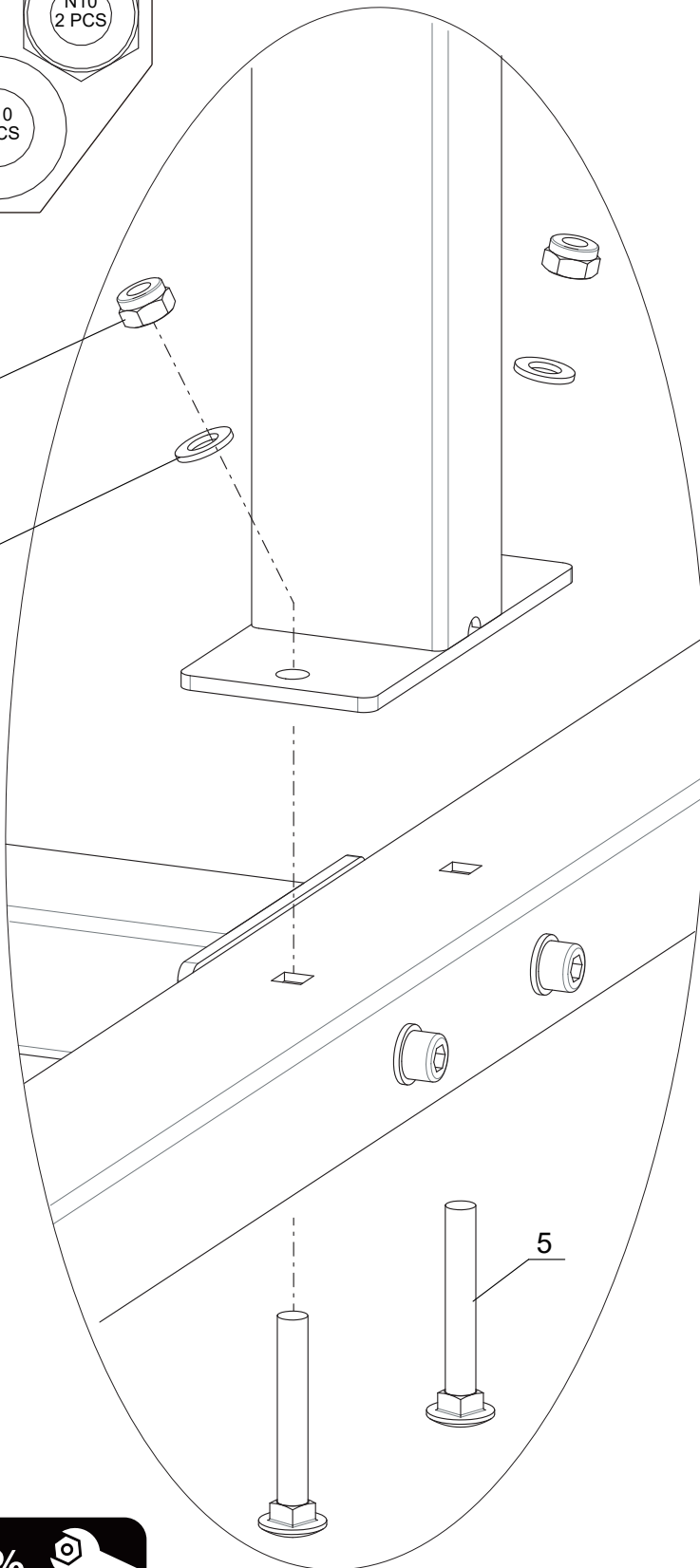

4

Parts

- Part No: 4
Name: Upright Support
Q'TY: 1
- Part No: 5
Name: Carriage Bolt
M10×70
Q'TY: 2



Tools



17 mm



50%



STEP 3

Install the Brace (#6).

Tools

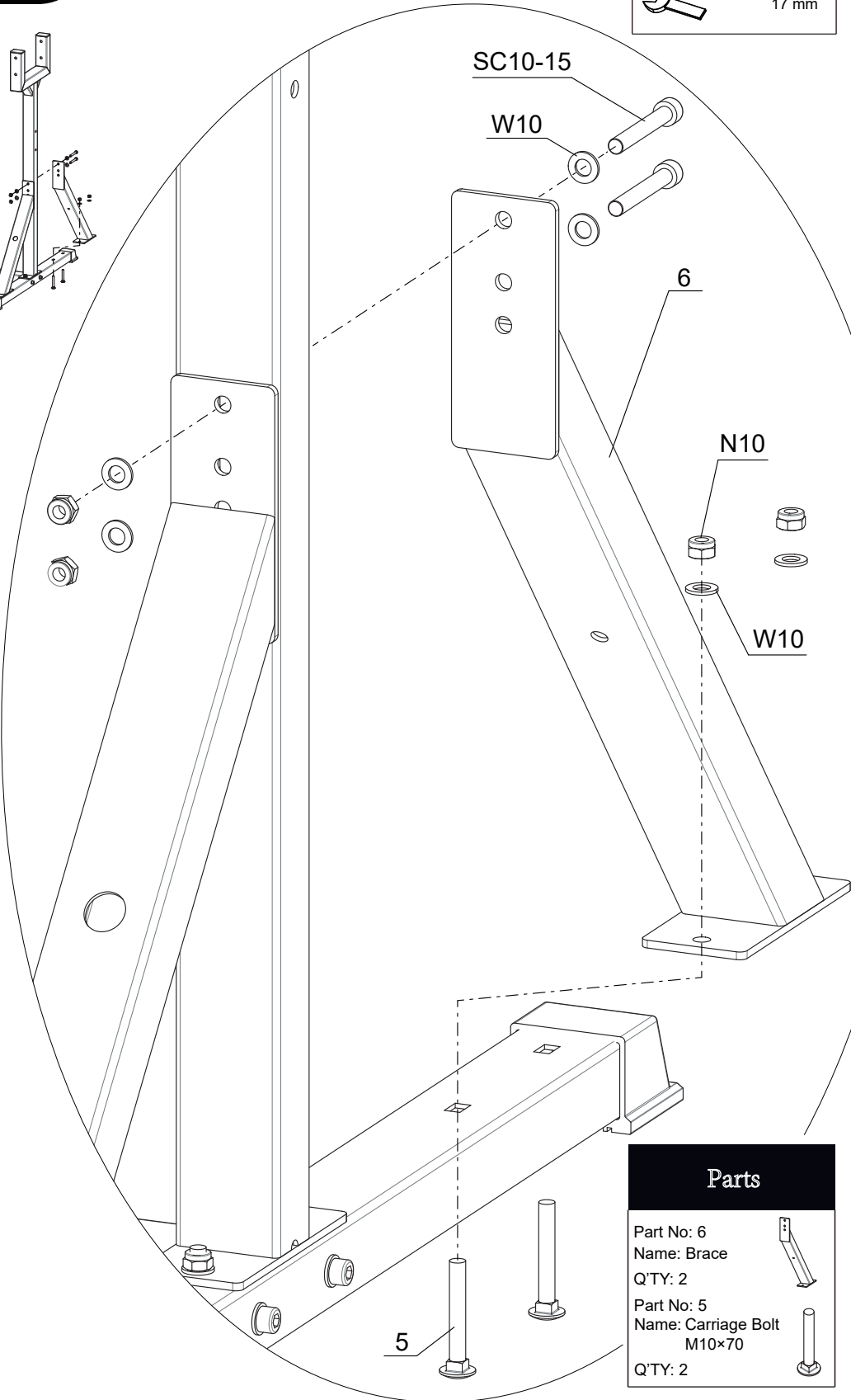
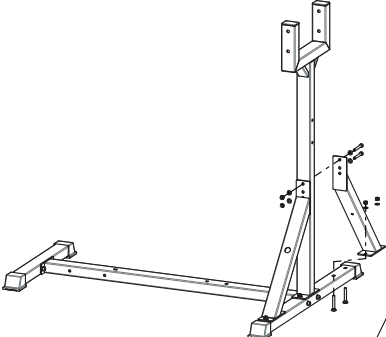

	8 mm
	17 mm



Fixings

S10-15 2 PCS	N10 6 PCS
W10 8 PCS	

Parts

Part No: 6 Name: Brace Q'TY: 2	
Part No: 5 Name: Carriage Bolt M10×70 Q'TY: 2	

50% 

Fixings

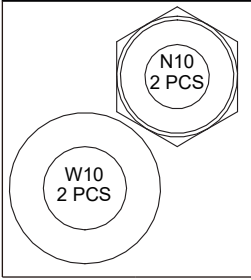

Install the Support Tube (#7).

STEP 4

Parts

- Part No: 7
Name: Support Tube
Q'TY: 1
- Part No: 5
Name: Carriage Bolt
M10x70
Q'TY: 2

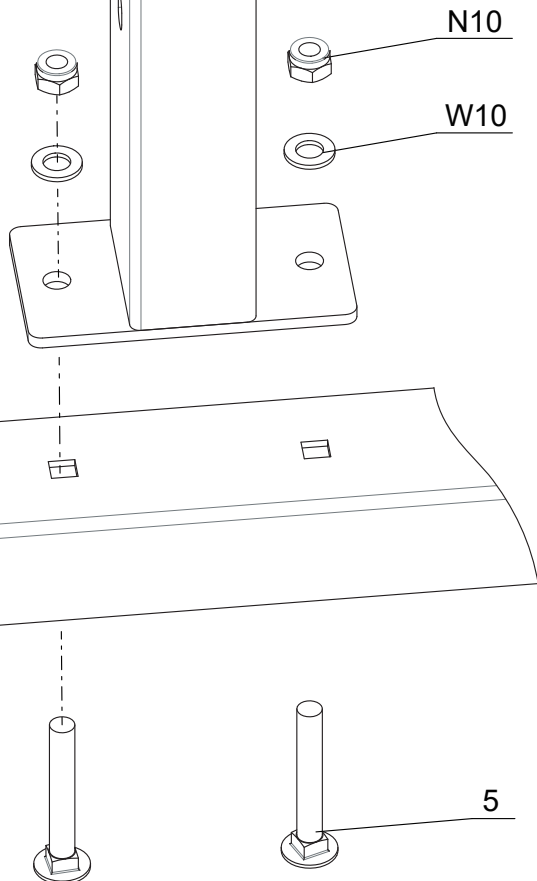
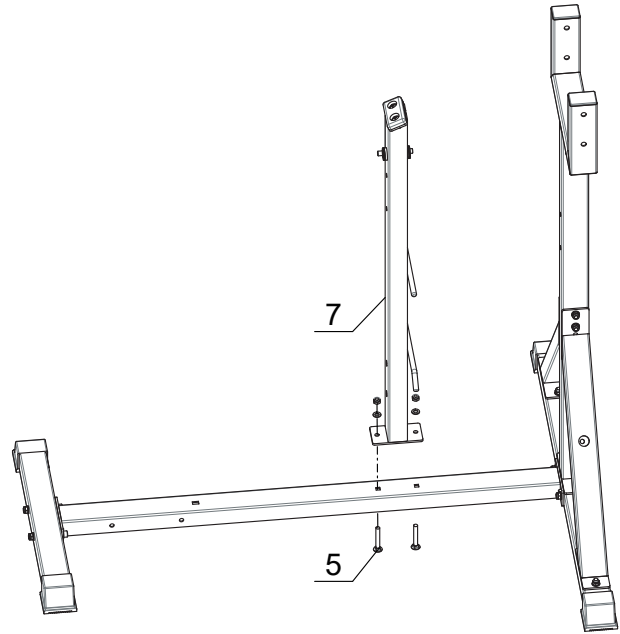

50%



Tools



17 mm

STEP 5

Install the Pedal (#8).

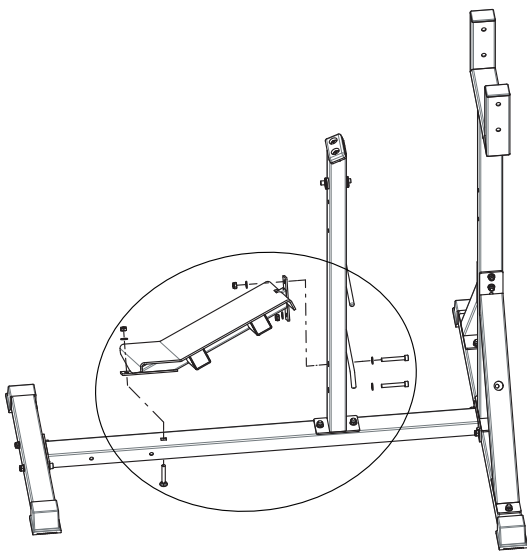

Parts

Part No:8
Name: Pedal
QTY: 1



Part No:5
Name: Carriage Bolt
M10x70
QTY: 1



Fixings

S10-14
2 PCS



N10
3 PCS

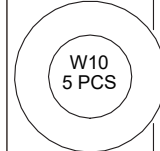

W10
5 PCS

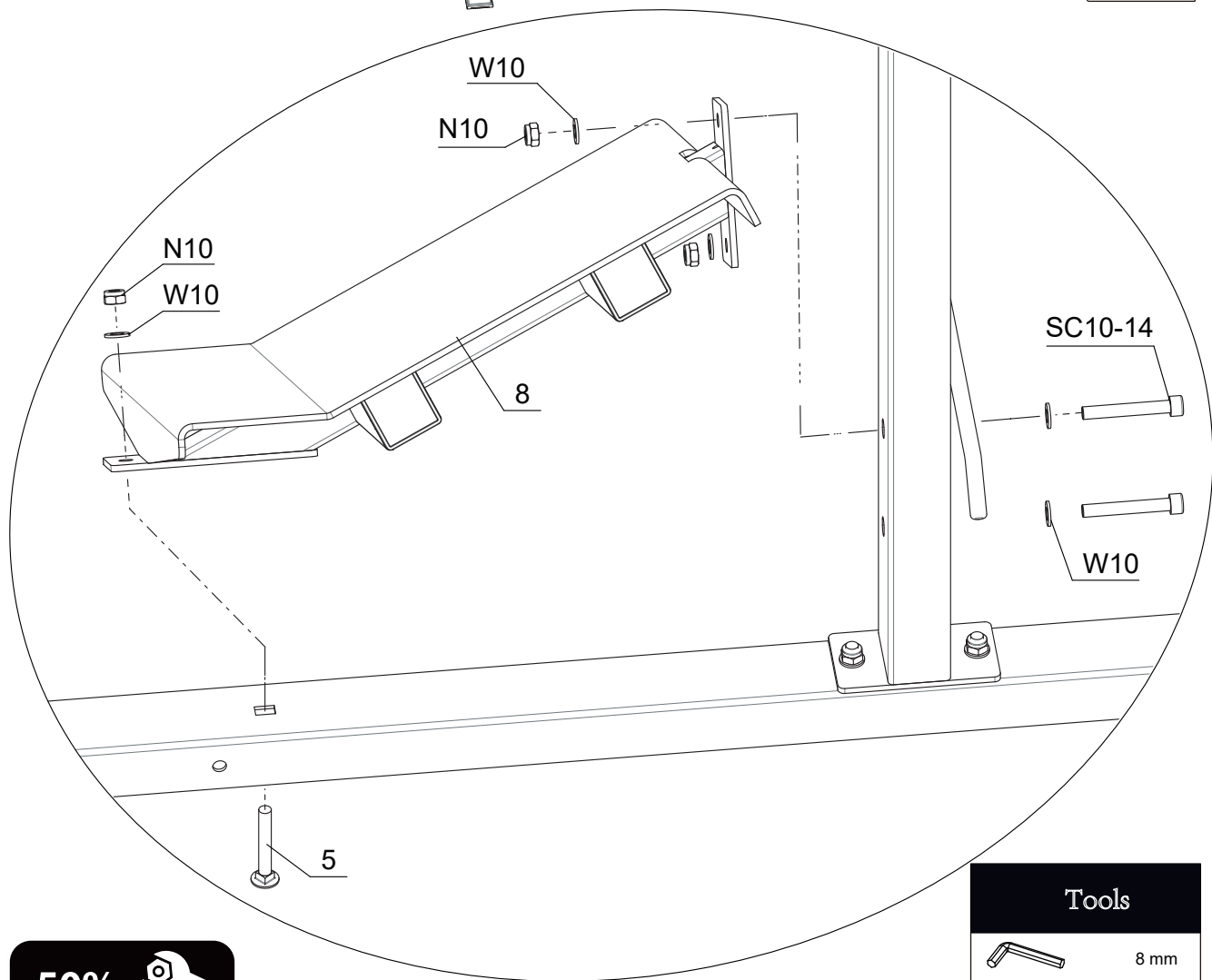

50%



Tools



8 mm



17 mm

Fixings

S10-18
2 PCS

N10
4 PCS

S10-14
2 PCS

W10
8 PCS

Install the Connection Tube (#9).

STEP 6

Parts

Part No: 9
Name: Connection Tube
Q'TY: 1

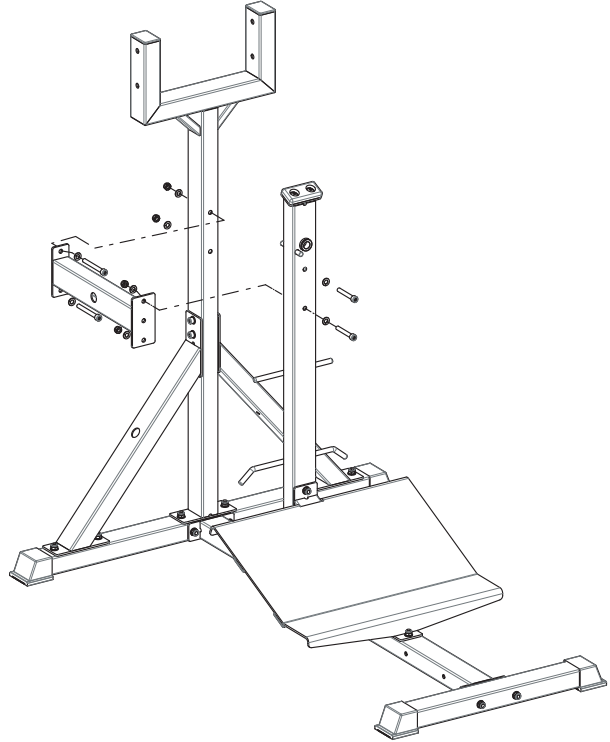

Tools

-  17 mm
-  8 mm

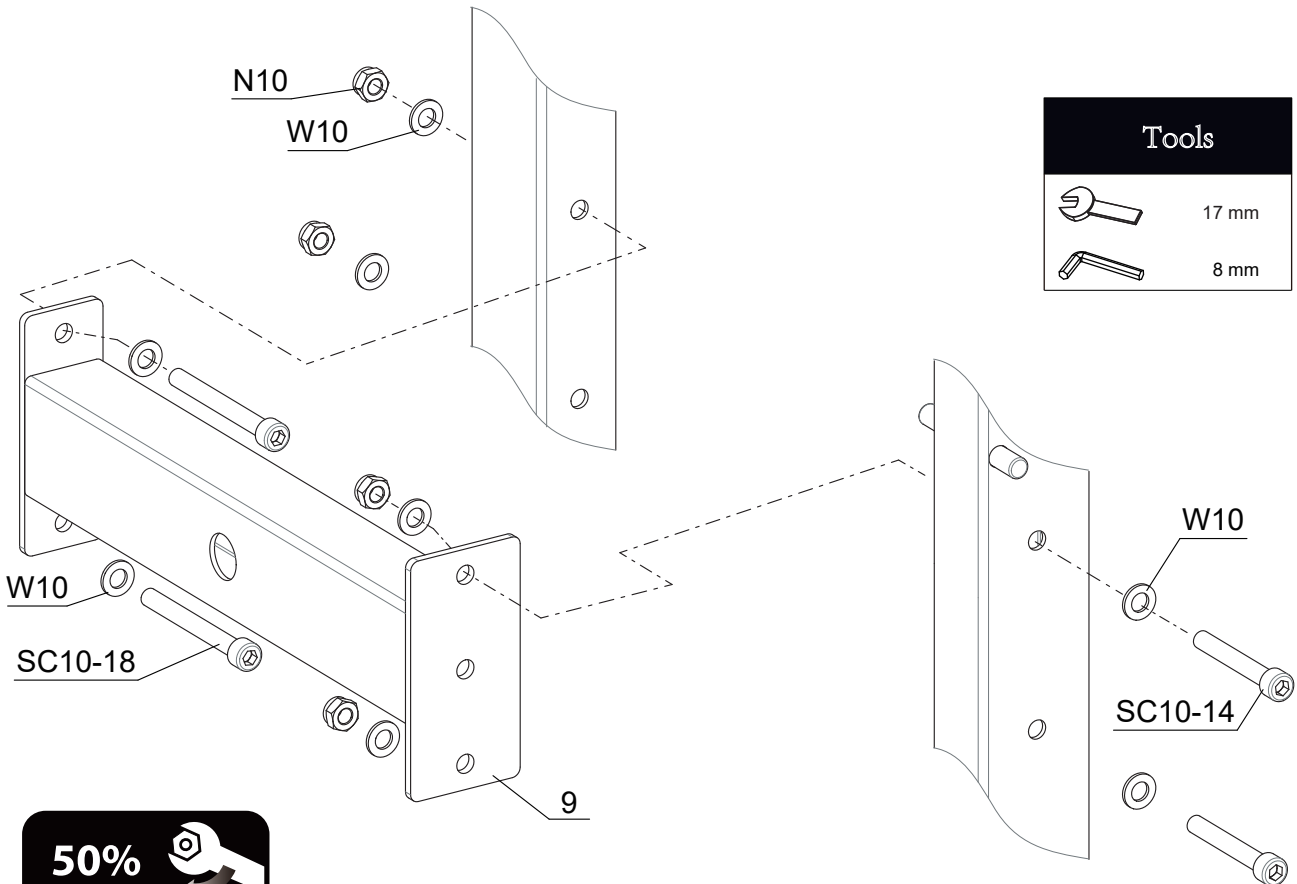

STEP 7

Install the Pedal (#10).

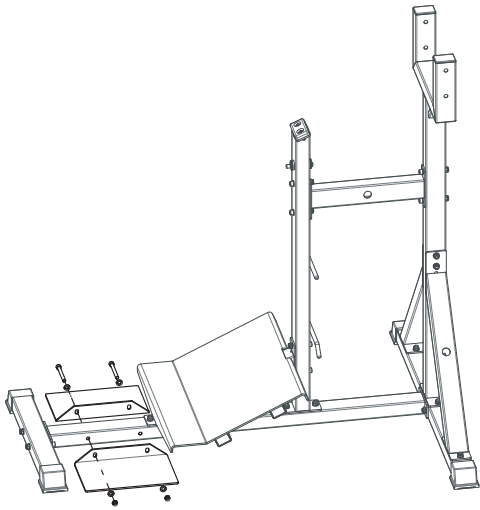

Parts

Part No:10
Name: Pedal
Q'TY: 2

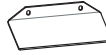

Tools

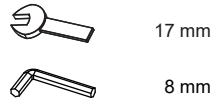

Fixings

SC10-19
2 PCS

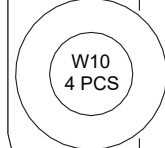
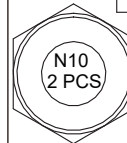

W10
4 PCS

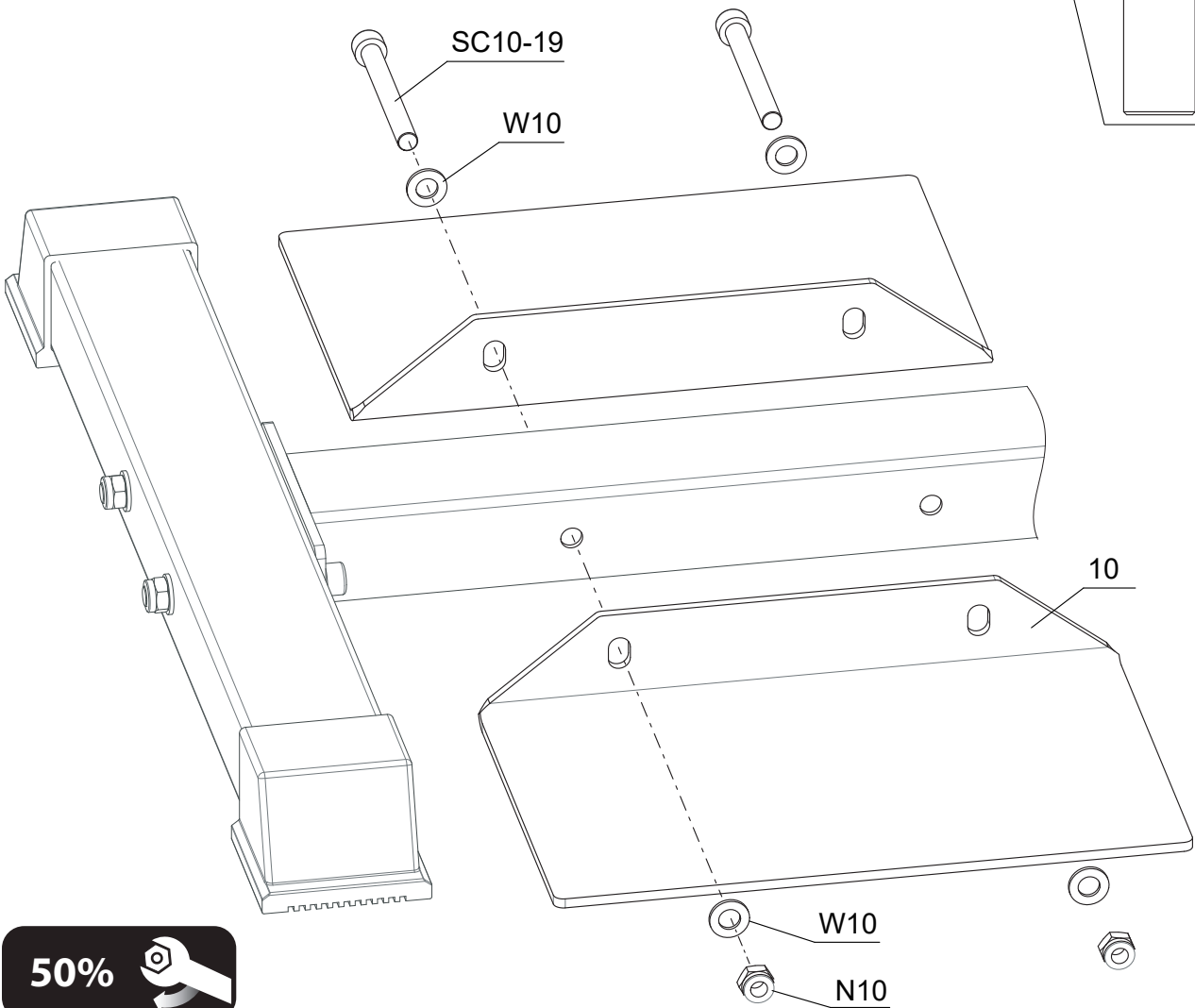

50%



Tools



Install the Swing Support (#11).

STEP 8

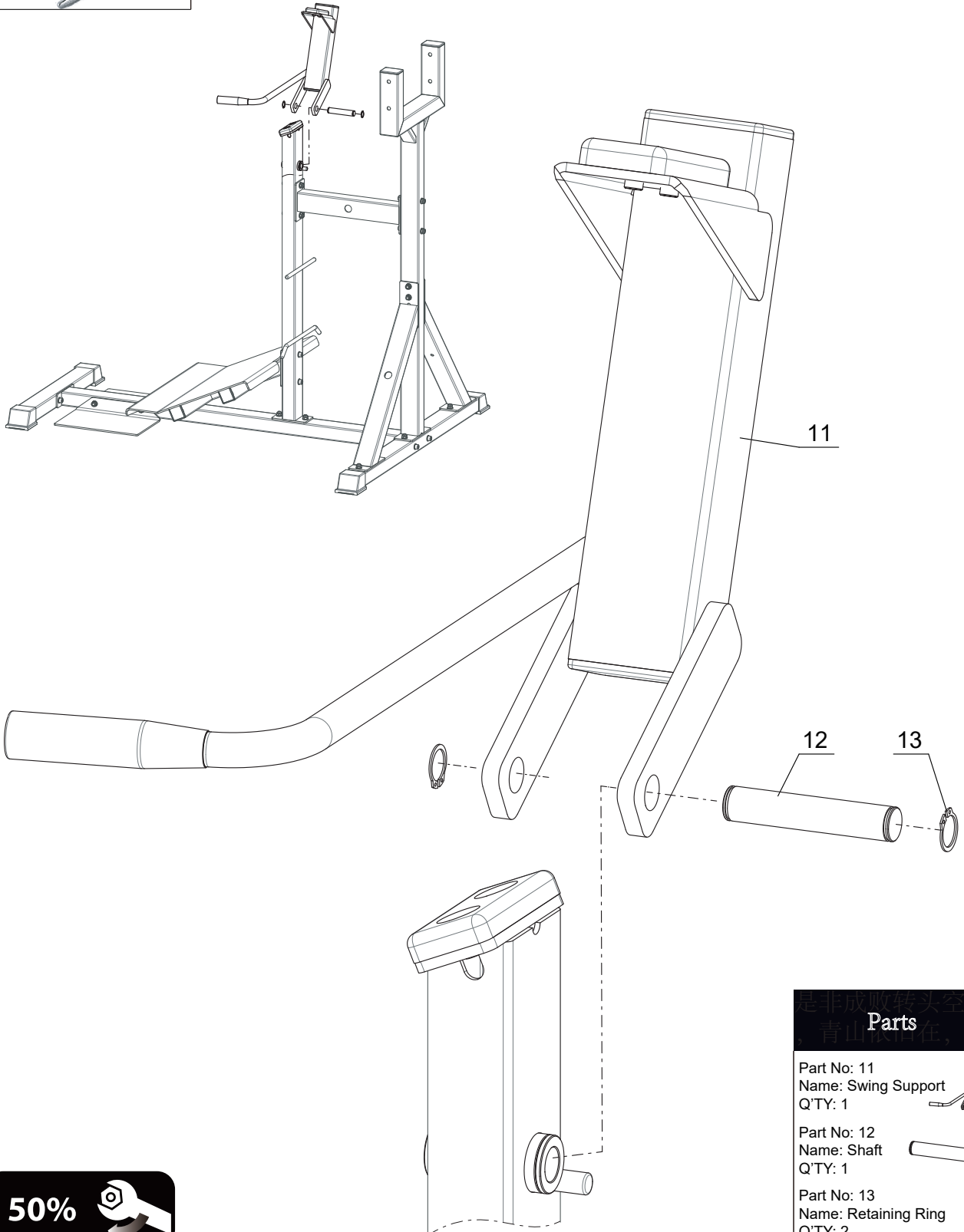

Parts

Part No: 11
Name: Swing Support
Q'TY: 1



Part No: 12
Name: Shaft
Q'TY: 1



Part No: 13
Name: Retaining Ring
Q'TY: 2

50%



STEP 9

Install the Swing Arm(#14).

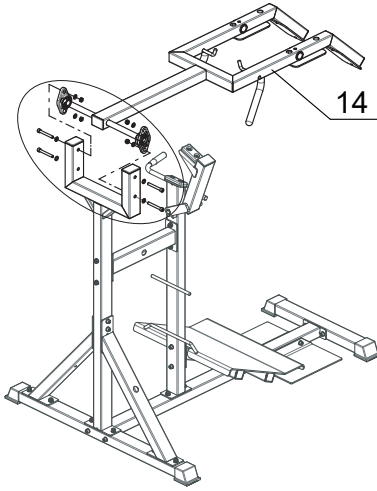

14

Parts

Part No:14
Name:
Swing Arm
Q'TY: 1

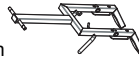

Fixings

S10-16
4 PCS

N10
4 PCS

W10
8 PCS

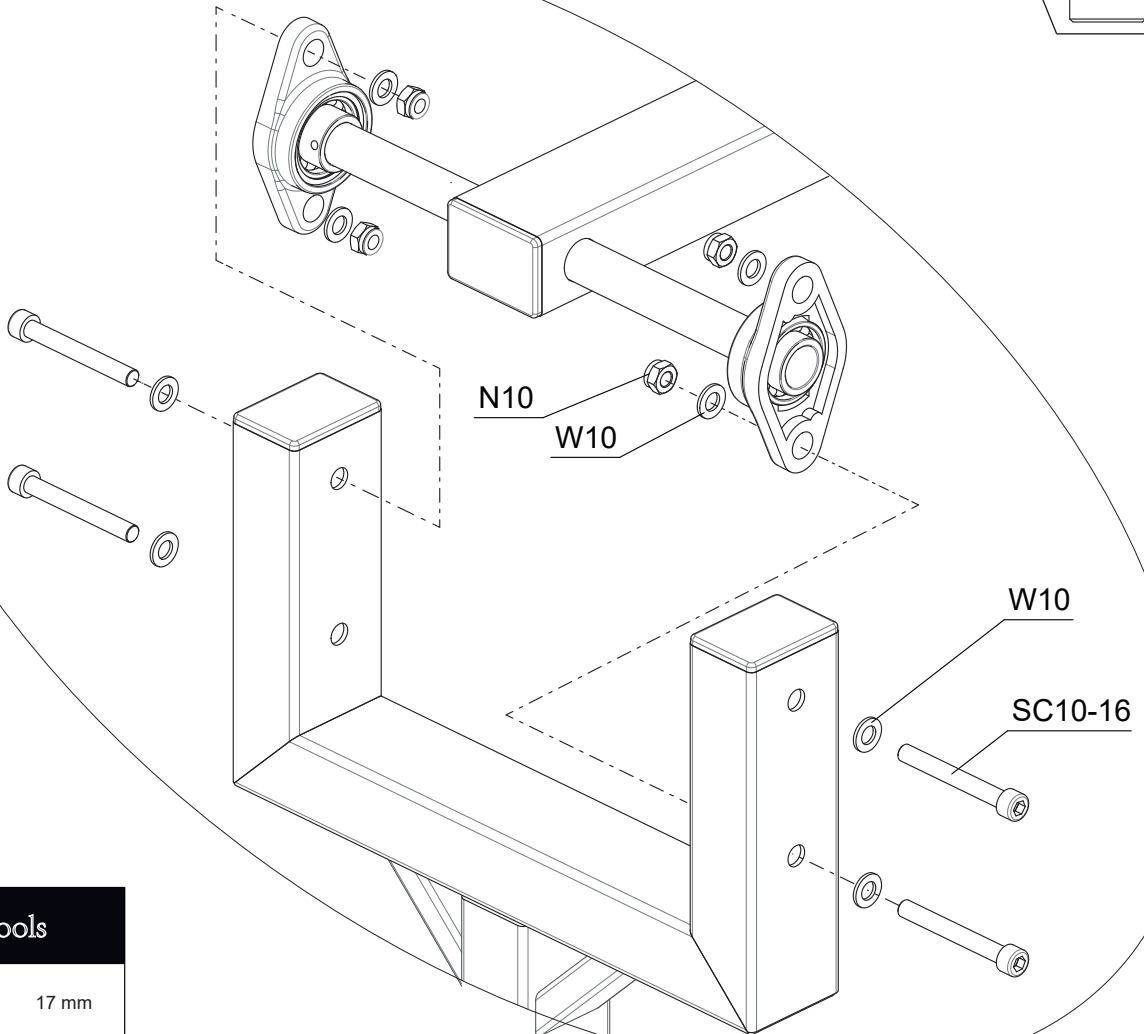

N10

W10

W10

SC10-16

Tools



17 mm



8 mm

Fixings

SC8-6
8 PCS

W8
8 PCS

Install the Pedal (#16).

STEP 10

Parts

Part No: 16
Name: Shoulder Pad
Q'TY: 4

Part No: 17
Name: D25 Hole Cap
Q'TY: 8

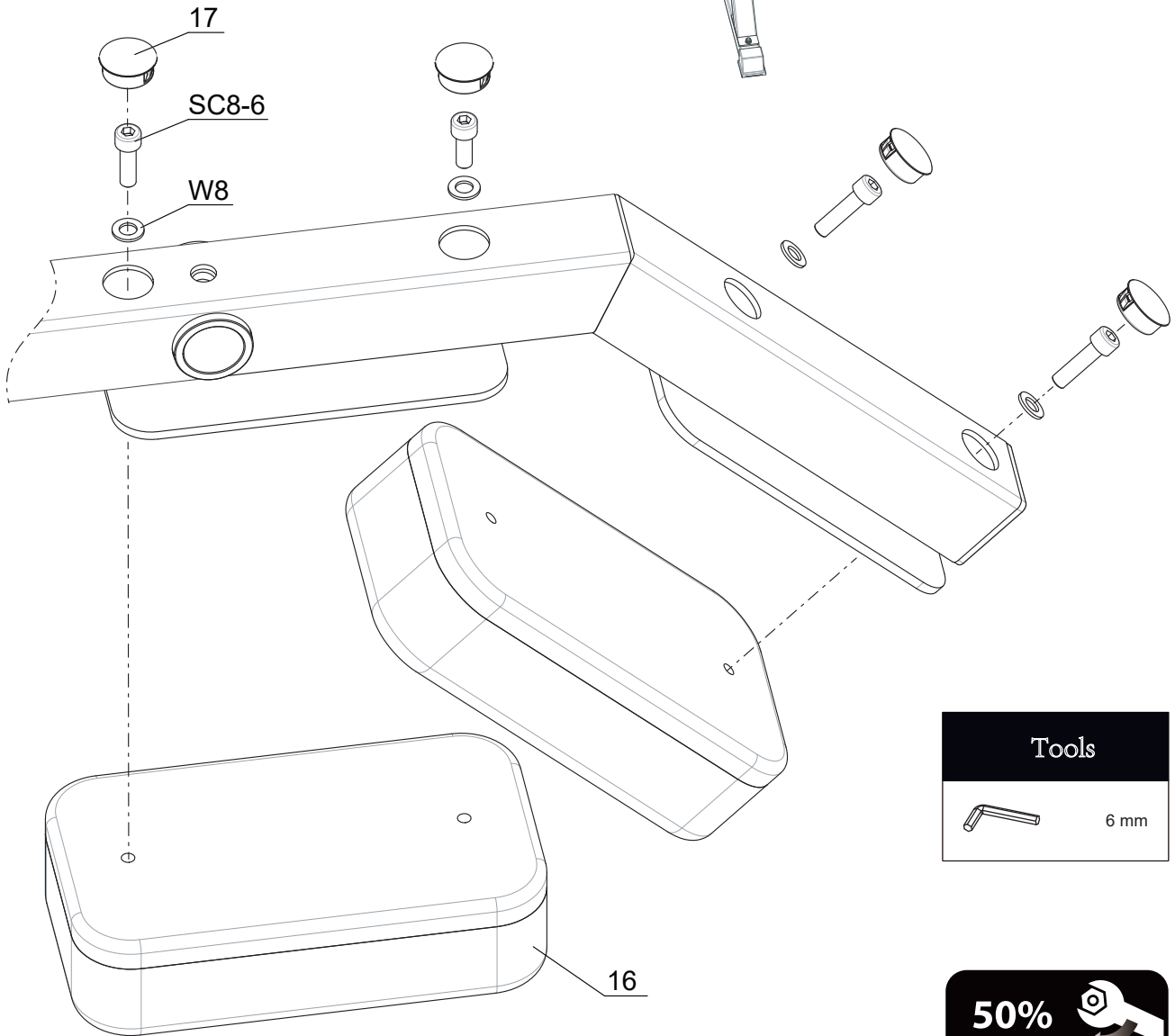
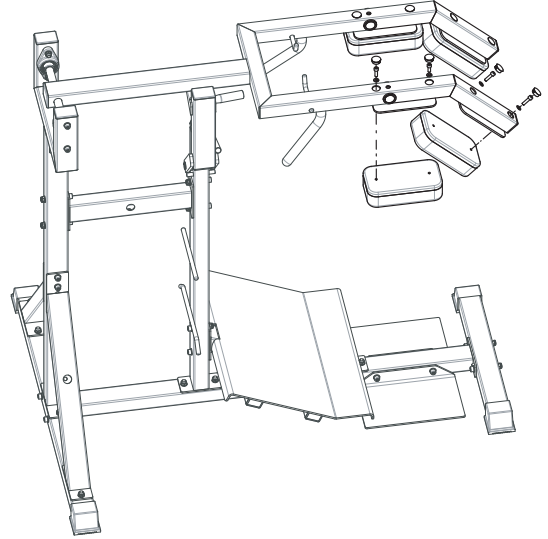

Tools



6 mm

50%



STEP 11

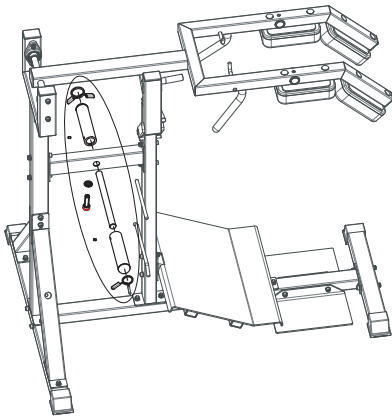

Install the Barbell Bar(#18).

Fixings



S8-2

Preassembled to the Barbell Sleeve.

SC10-7
1 PC

W10
1 PC

Parts

- Part No:18  Name: Barbell Bar Q'TY: 1
- Part No:19  Name: Barbell Sleeve Q'TY: 2
- Part No:20  Name: Barbell Collar Q'TY: 2

Tools



4 \ 8 mm

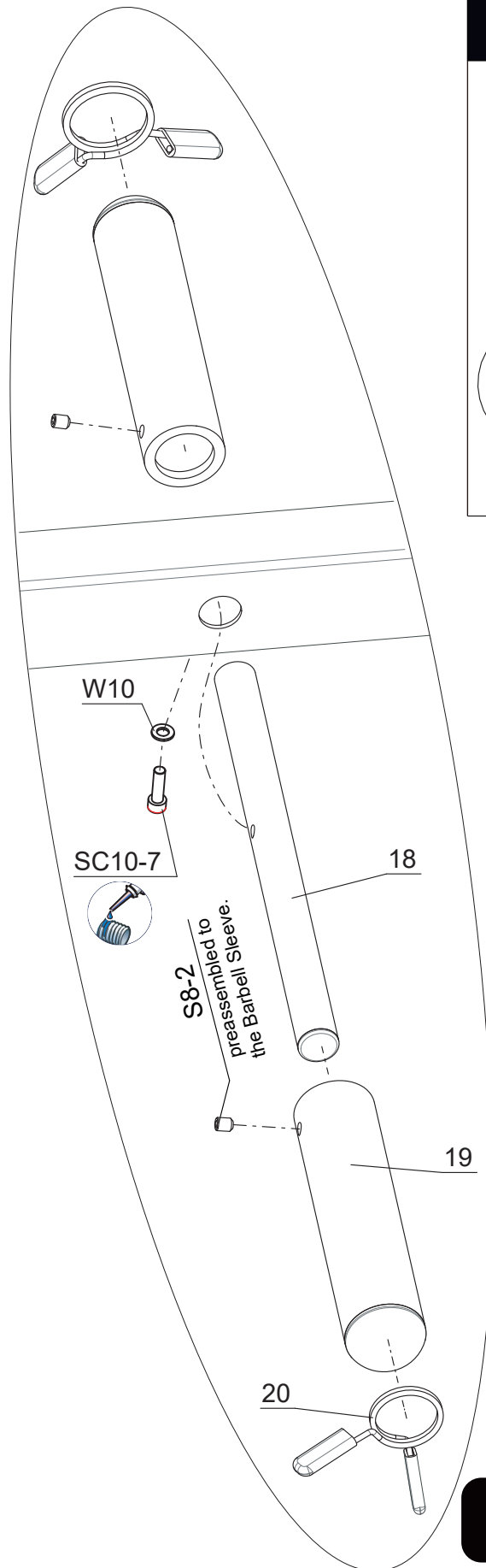

50%



Tools



8 mm

Install the Storage Bar (#21).

STEP 12

Parts

Part No:21
Name: Storage Bar
Q'TY: 2

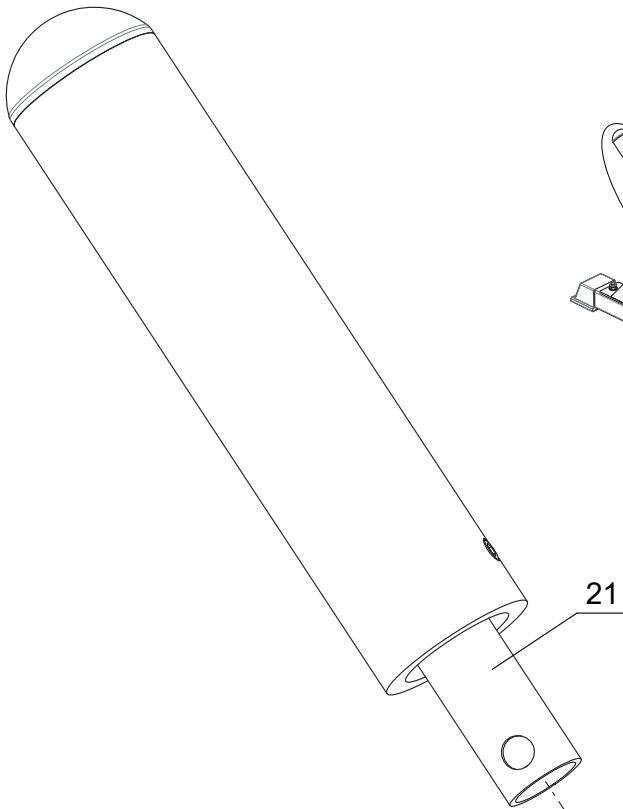
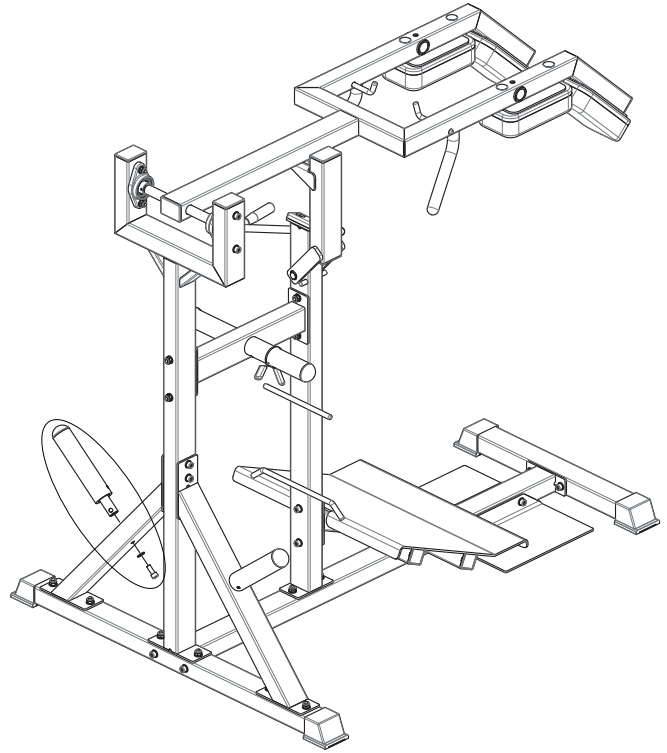

21

Fixings

SC10-5
2 PCS

W10
2 PCS

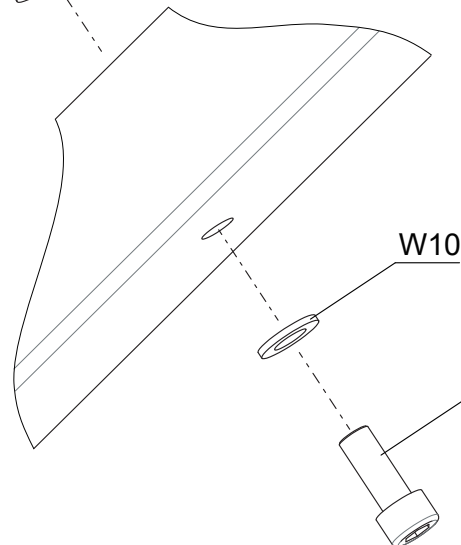

W10

SC10-5



100%



STEP 13

Install the Barbell Bar (#15).

Parts

Part No:20
Name: Barbell Collar
Q'TY: 2

Part No:15
Name: Barbell Bar
Q'TY: 2

Fixings

SC12-6
2 PCS

W8B
2 PCS

Tools

10 mm

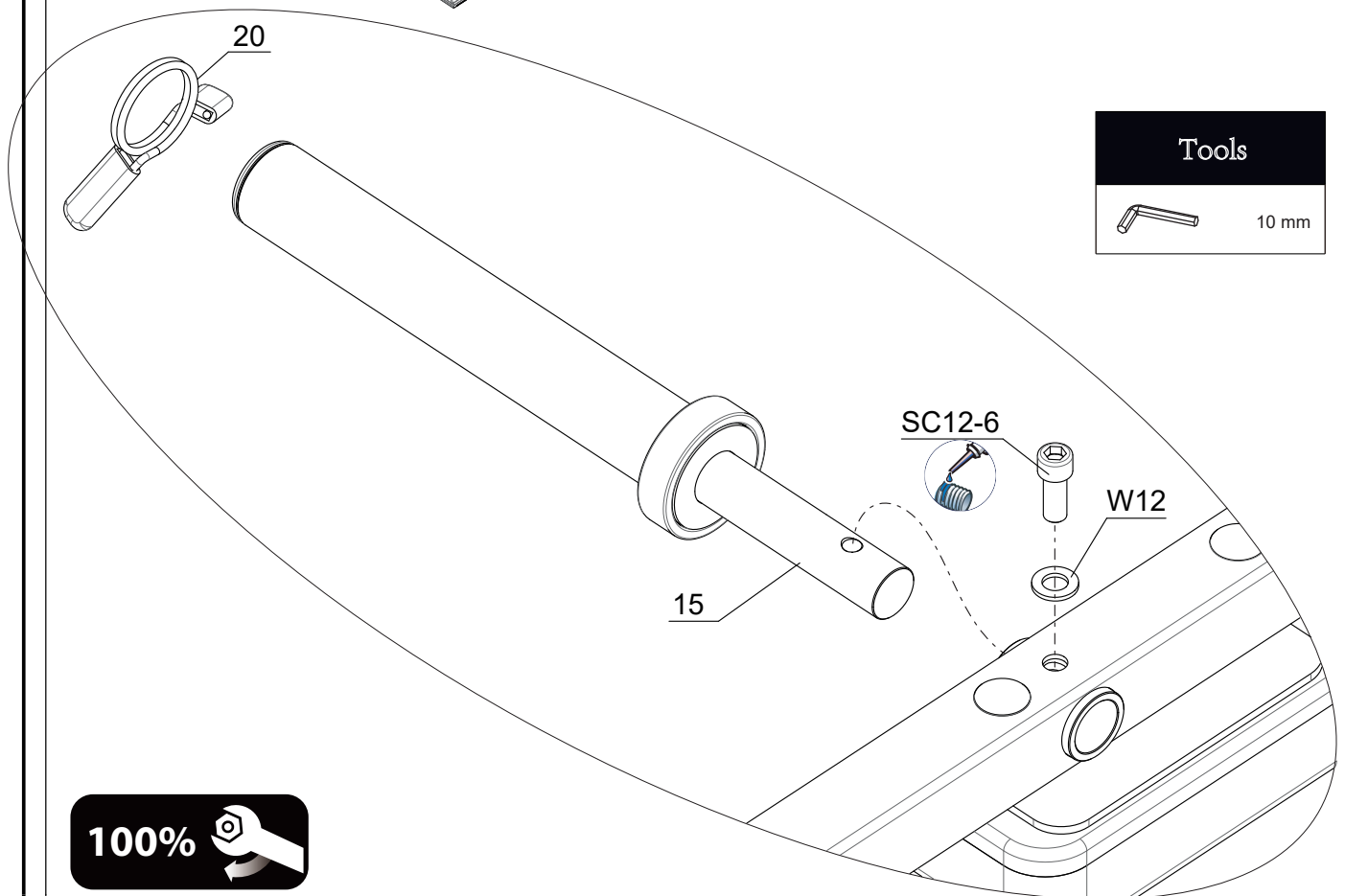
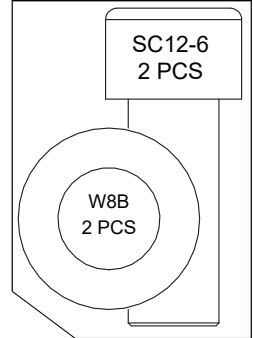
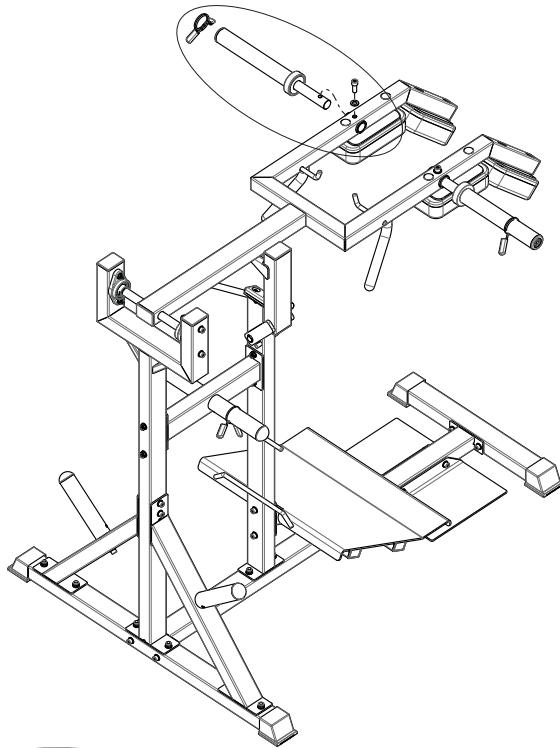

100%



PARTS LIST

PART#	DESCRIPTION	Qty
1	Bottom Lateral Tube	1
2	Bottom Lateral Tube	1
3	Lengthwise Tube	1
4	Upright Support	1
5	Carriage Bolt M10×70	9
6	Brace	2
7	Support Tube	1
8	Pedal	1
9	Connection Tube	1
10	Pedal	2
11	Swing Support	1
12	Shaft	1
13	Retaining Ring	2
14	Swing Arm	1
15	Barbell Bar	2
16	Shoulder Pad	4
17	D25 Hole Cap	8

PART#	DESCRIPTION	Qty
18	Barbell Bar	1
19	Barbell Sleeve	2
20	Barbell Collar	4
21	Storage Bar	2
N10	Lock Nut M10	27
SC8-6	Socket Head Cap Screw M8×30	8
SC10-5	Socket Head Cap Screw M10×25	2
SC10-7	Socket Head Cap Screw M10×35	1
SC10-14	Socket Head Cap Screw M10×70	4
SC10-15	Socket Head Cap Screw M10×75	2
SC10-16	Socket Head Cap Screw M10×80	4
SC10-18	Socket Head Cap Screw M10×90	6
SC10-19	Socket Head Cap Screw M10×95	2
W8	Plain Washer 8	8
W10	Plain Washer 10	48