

BLK BOX

Plate Loaded Leg Press

Setup Instructions

 CAUTION: Read all precautions and instructions before using this equipment. Save this manual for future reference.



Table Of Contents

Assembly Instructions.....2-12

Part List..... 13

To Apply Thread Locker

The Fasteners marked by the sign  in the following assembling steps need to be bonded to prevent loosening, or the fasteners are a type of thread locking screws.

How to use

1. Degrease and clean surfaces prior to apply adhesive.
2. Insert bolt and apply adhesive to the exposed thread. Assemble nut and tighten to the correct torque (FIG 1).
3. Apply several drops of adhesive down the sides of the blind hole filling the lower third. Apply several drops to the bolt, Assemble and tighten (FIG 2).

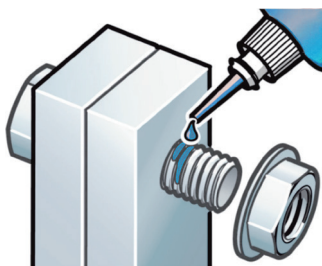
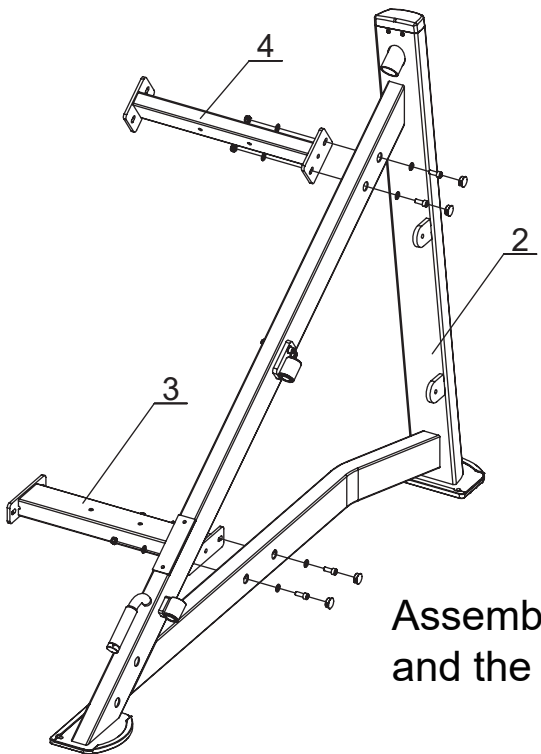

FIG 1



FIG 2

STEP 1



Parts	
Part No: 2 Name: Main Frame 2 Q'TY: 1	
Part No: 3 Name: Crosswise Tube 1 Q'TY: 1	
Part No: 4 Name: Crosswise Tube 2 Q'TY: 1	
Part No: 5 Name: Hole Cap Q'TY: 4	

Fixings	
	N10 4 PCS
	SC10-5 4 PCS
	W10 8 PCS

Tools	
	8 mm
	17 mm

Assemble the Main Frame 2(#2) and the Crosswise Tube(#3 & #4).

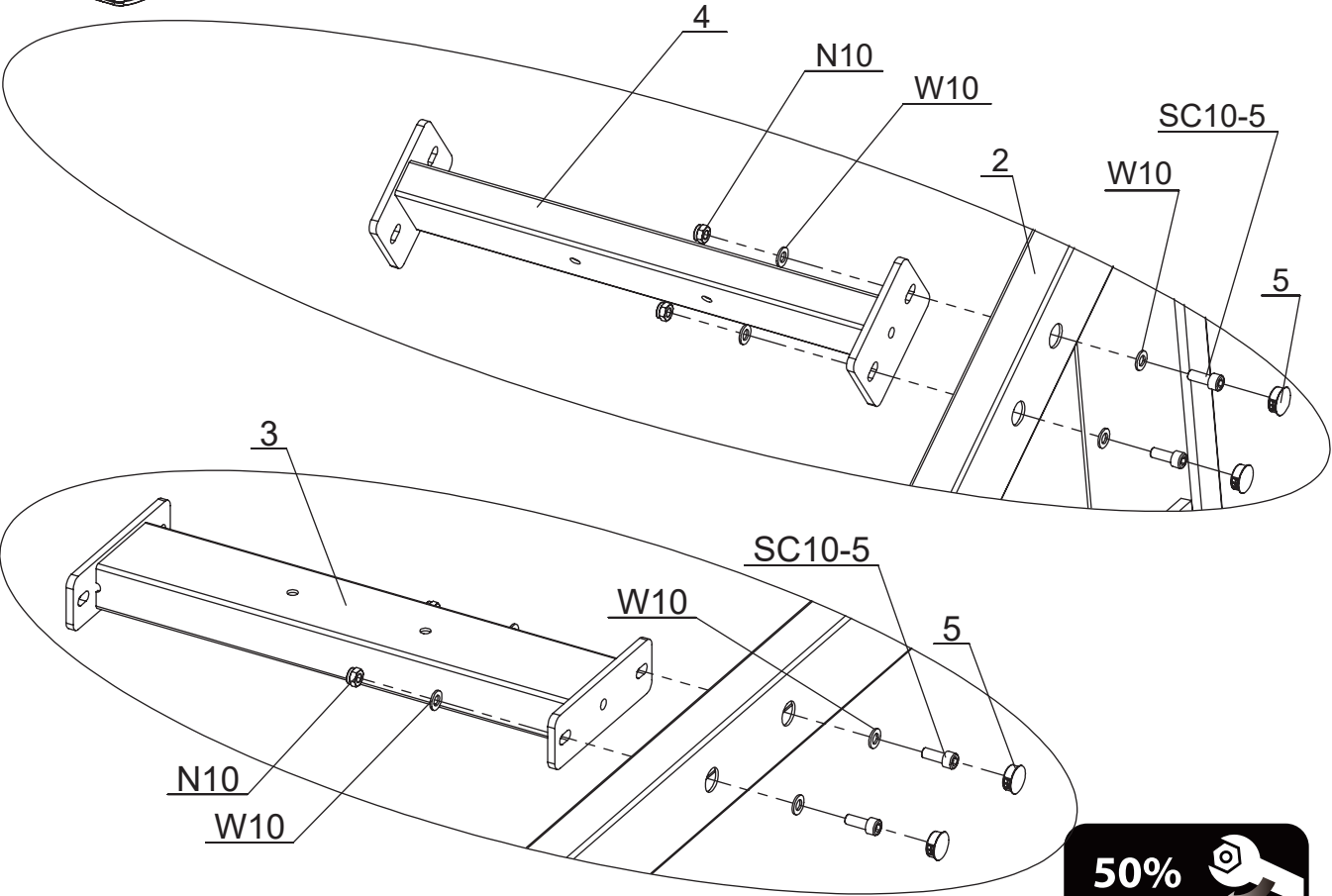



STEP 2

Parts

Part No: 1
Name: Main Frame 1
Q'TY: 1



Tools

 8 mm
 17 mm

Fixings

SC10-5 4 PCS
N10 4 PCS
W10 8 PCS

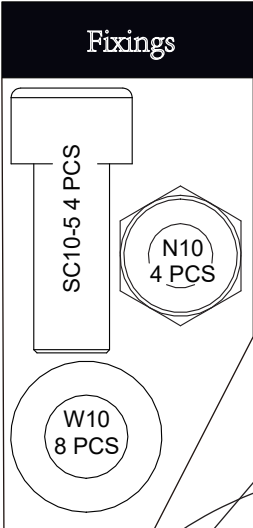

Install the Main Frame 1 (#1).

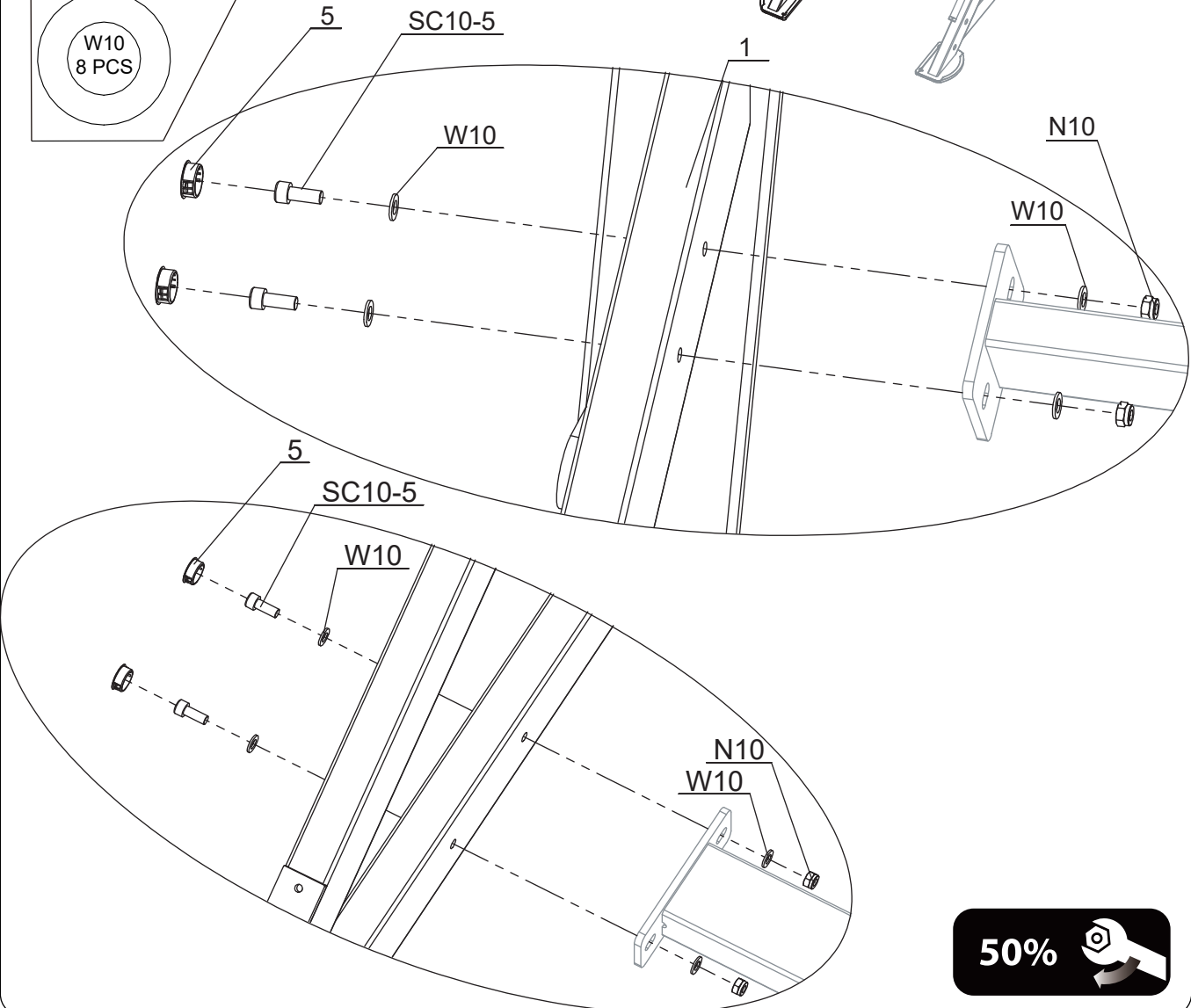
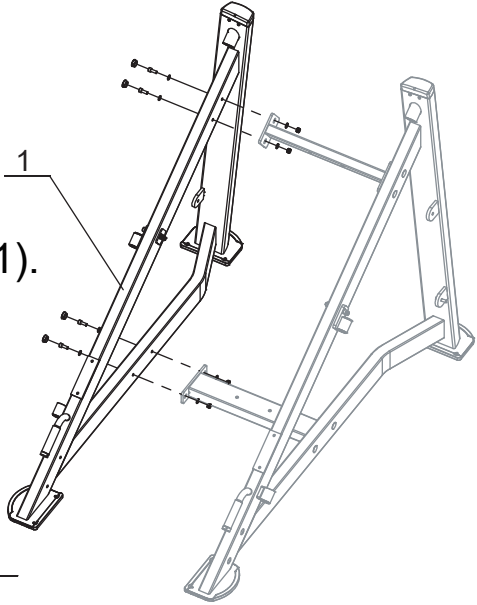

50% 

STEP 3

Install the Barbell Sleeve (#6).

Parts

Part No: 6
Name: Barbell Sleeve
Q'TY: 4



Tools



8 mm

Fixings

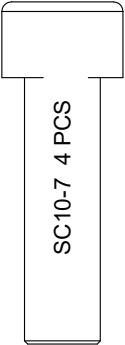

SC10-7 4 PCS



W10
4 PCS

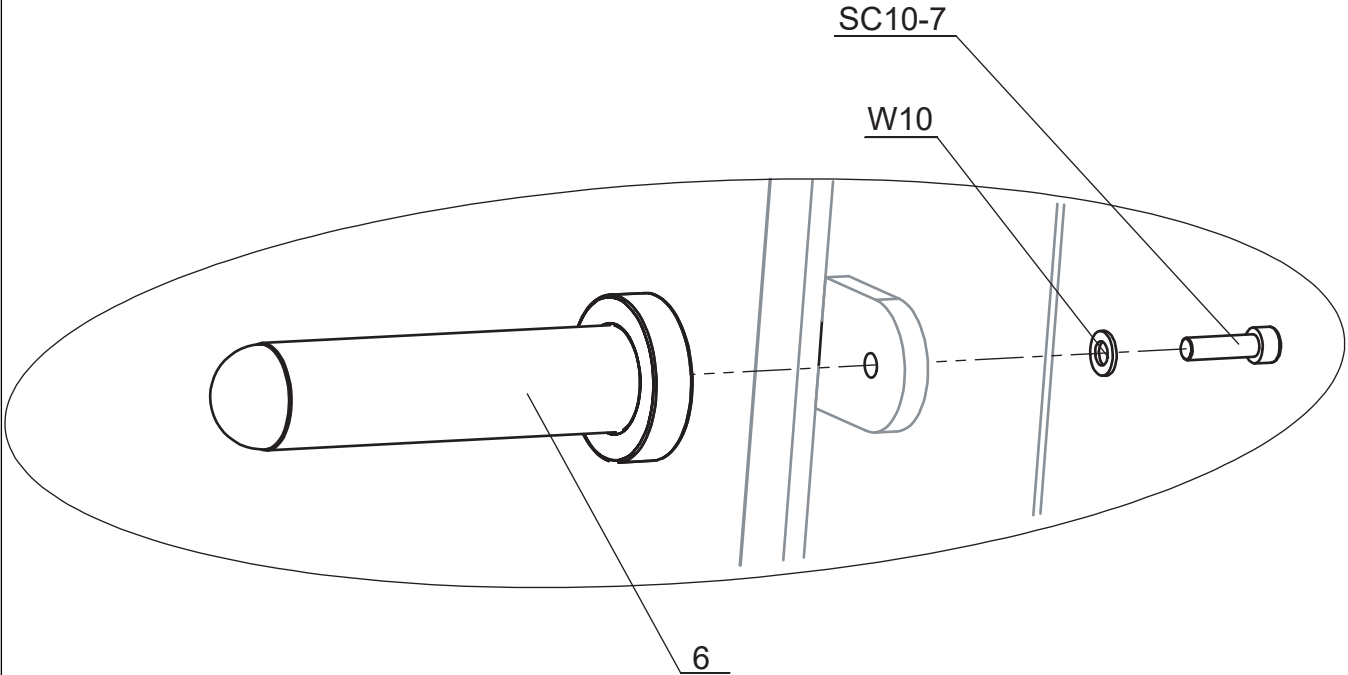
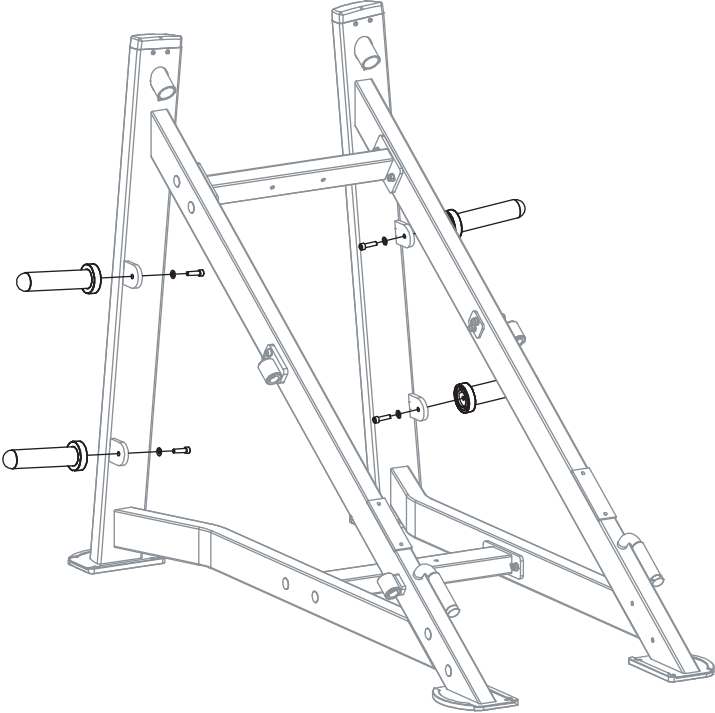

50%



Parts

Part No: 7
Name: Pedal Limit Assy
Q'TY: 1



Part No: 8
Name: Pad Plate
Q'TY: 1



Part No: 5
Name: Hole Cap
Q'TY: 2



Tools



8 mm



17 mm

STEP 4

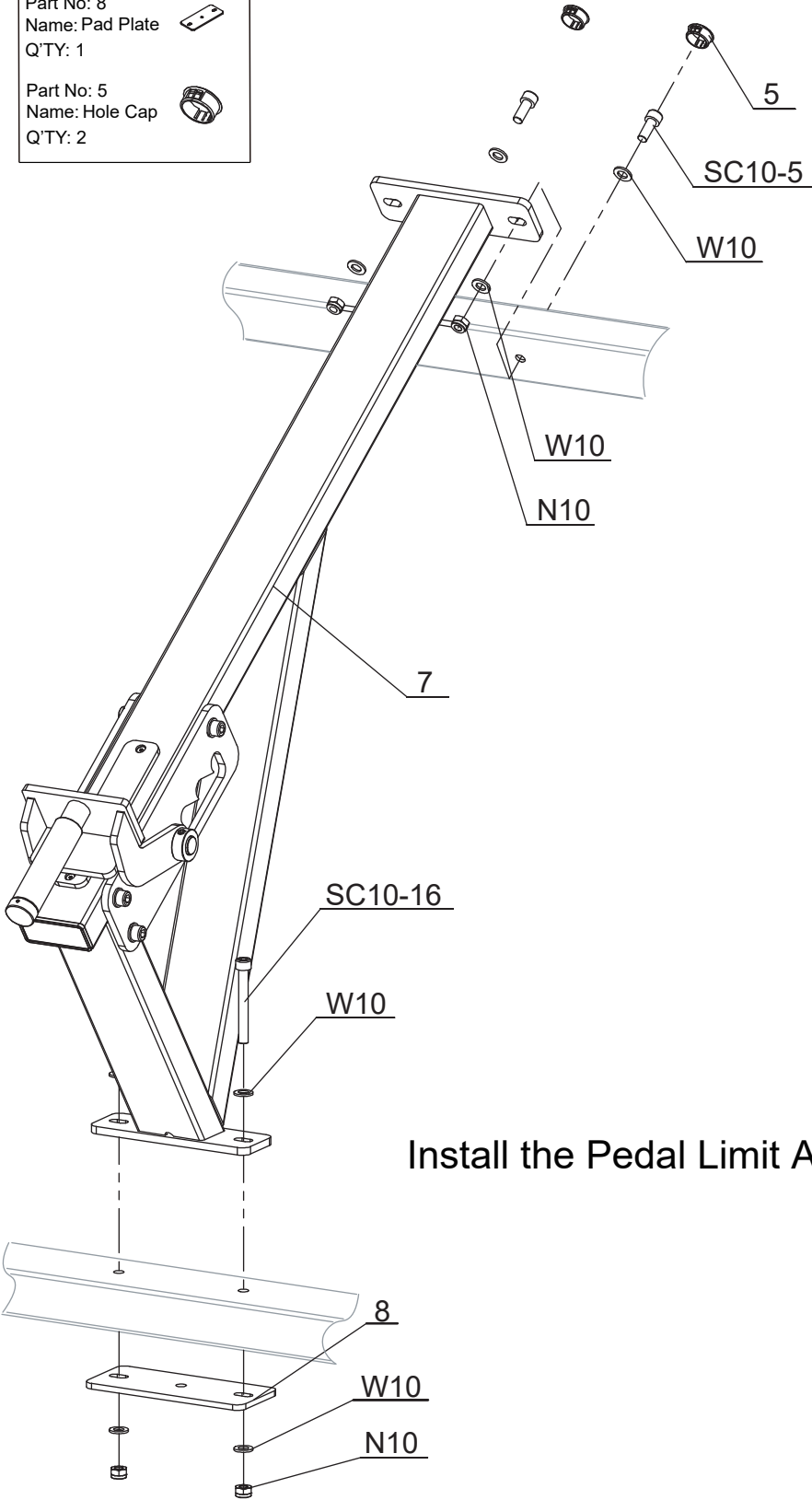
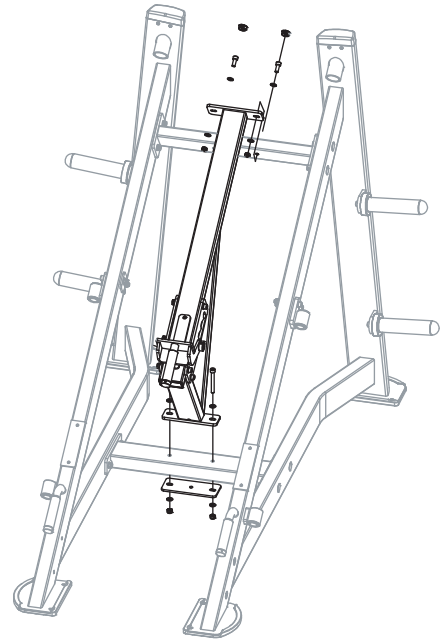



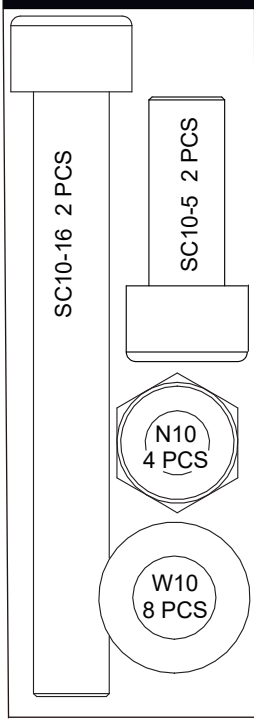

Install the Pedal Limit Assy (#7).

Fixings





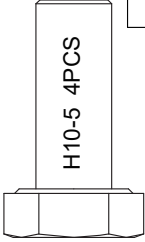
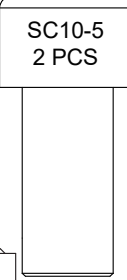

STEP 5

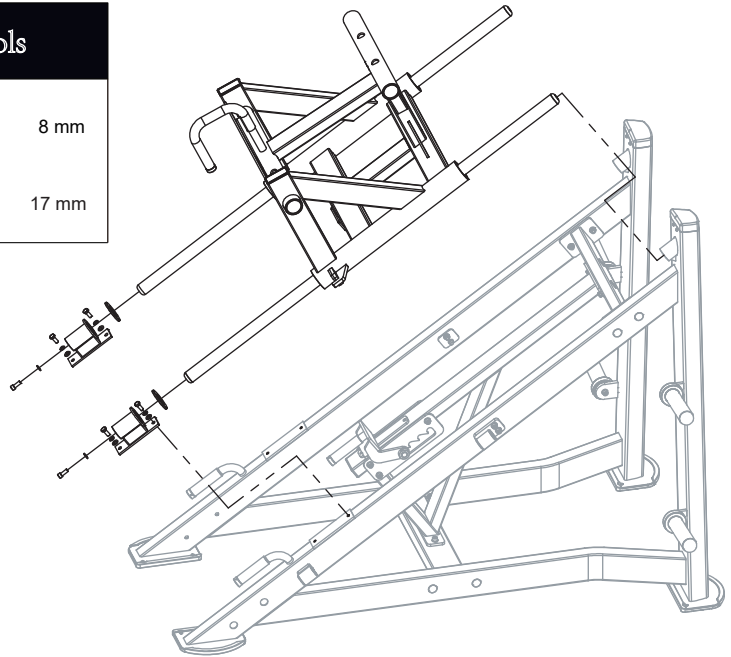
Tools	
	8 mm
	17 mm

Fixings	
	H10-5 4PCS
	SC10-5 2 PCS
	W12 6 PCS

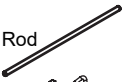

Install the Sliding Frame Assy (#12).

Parts	
Part No:9 Name: Bushing Q'TY: 2	
Part No:10 Name: S Q'TY: 2	
Part No:11 Name: Guide Rod Q'TY: 2	
Part No:12 Name: Holding Frame Q'TY: 1	

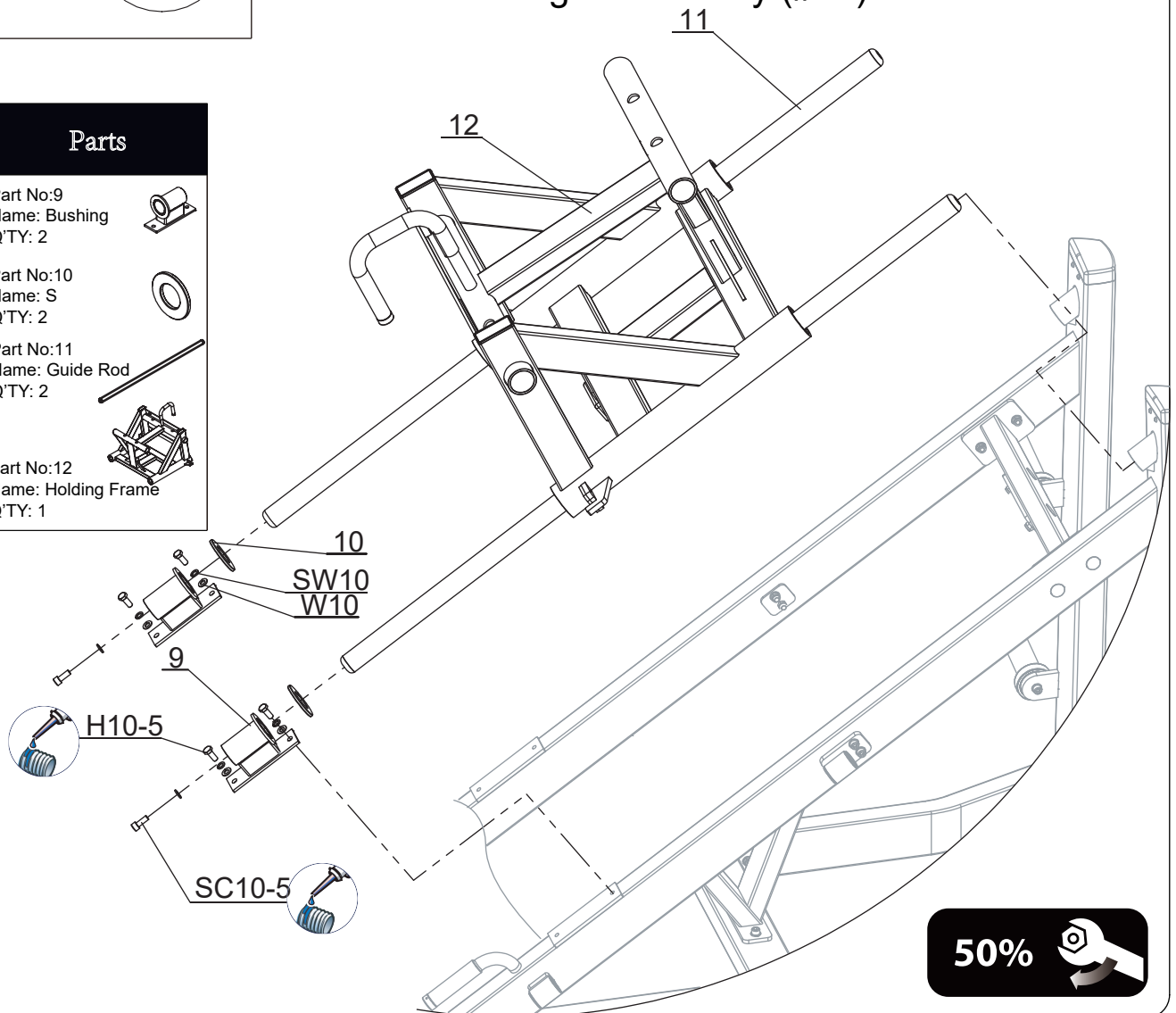

STEP 6

Fixings

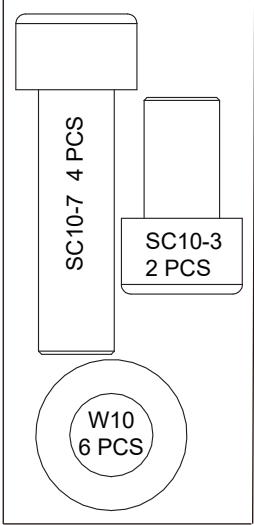

Parts

Part No: 14
Name: Pedal
Q'TY: 1

Part No: 13
Name: Function Board
Q'TY: 1

Install the Function Board (#13) and the Pedal (#14).

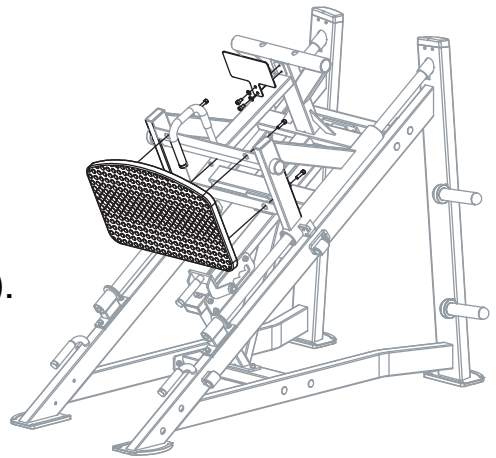

Tools

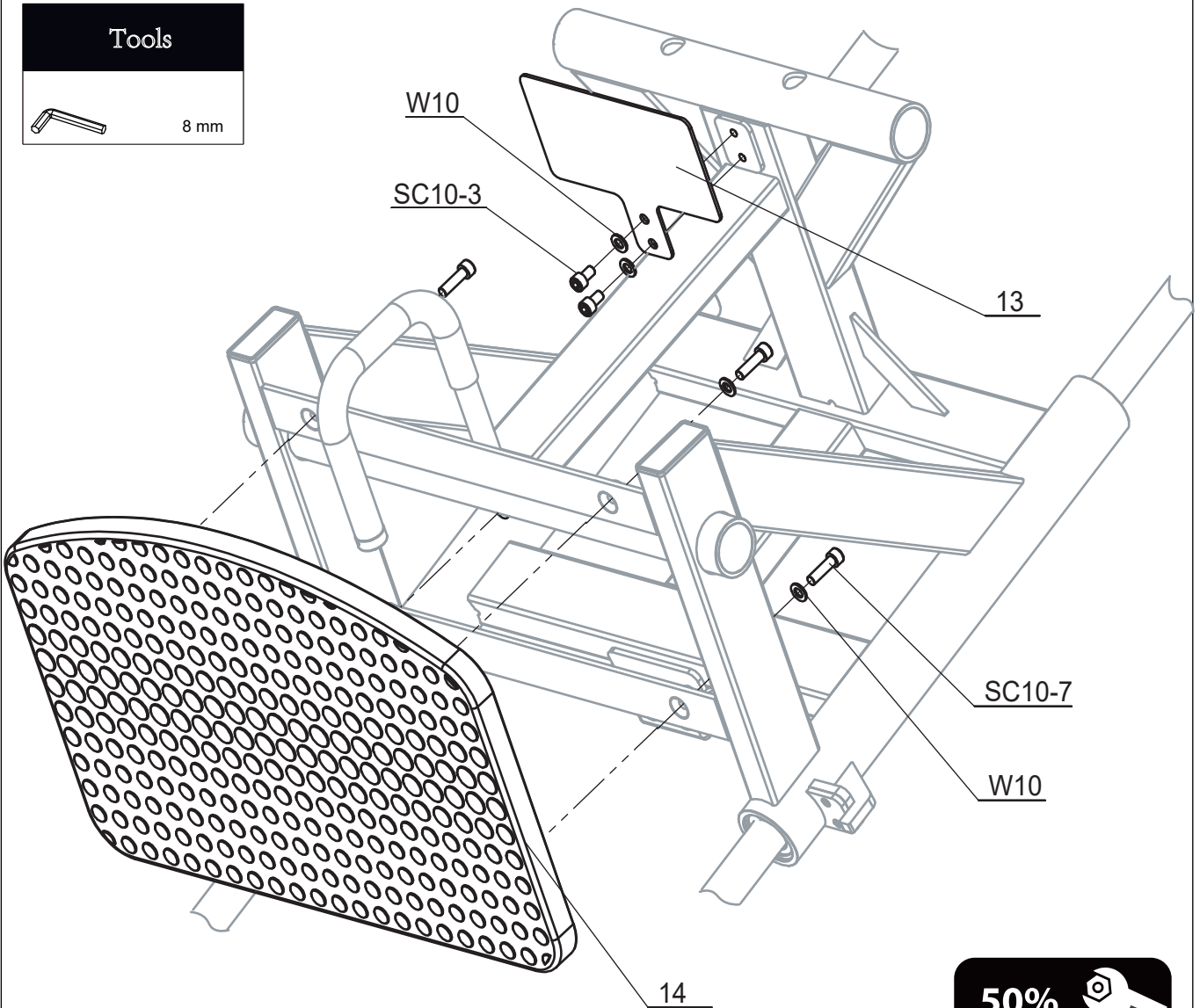

STEP 7

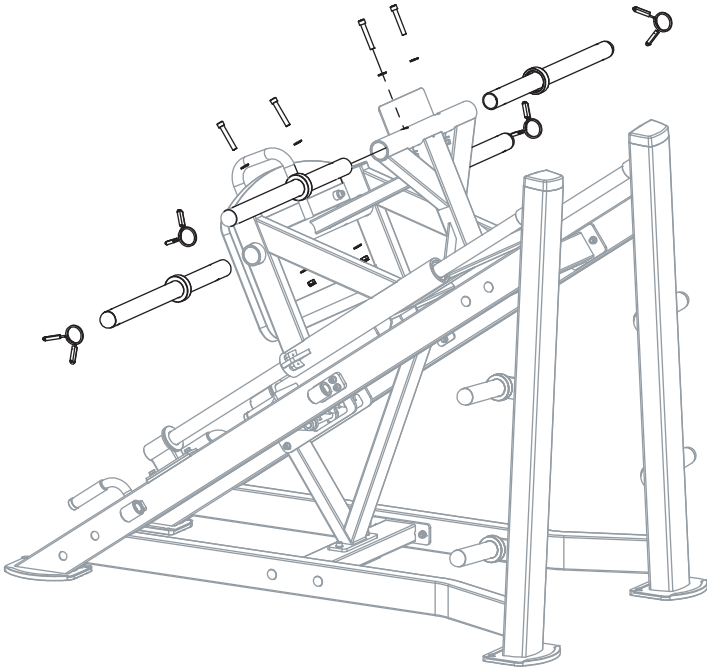

Parts

Part No: 15
Name: Weight Bar
Q'TY: 4

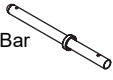

Part No: 16
Name: Barbell Clip
Q'TY: 4



Tools

 10 mm

 19 mm

Fixings

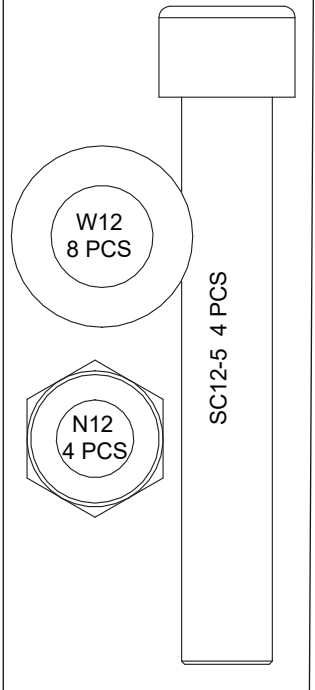

Install the Weight Bar (#15).

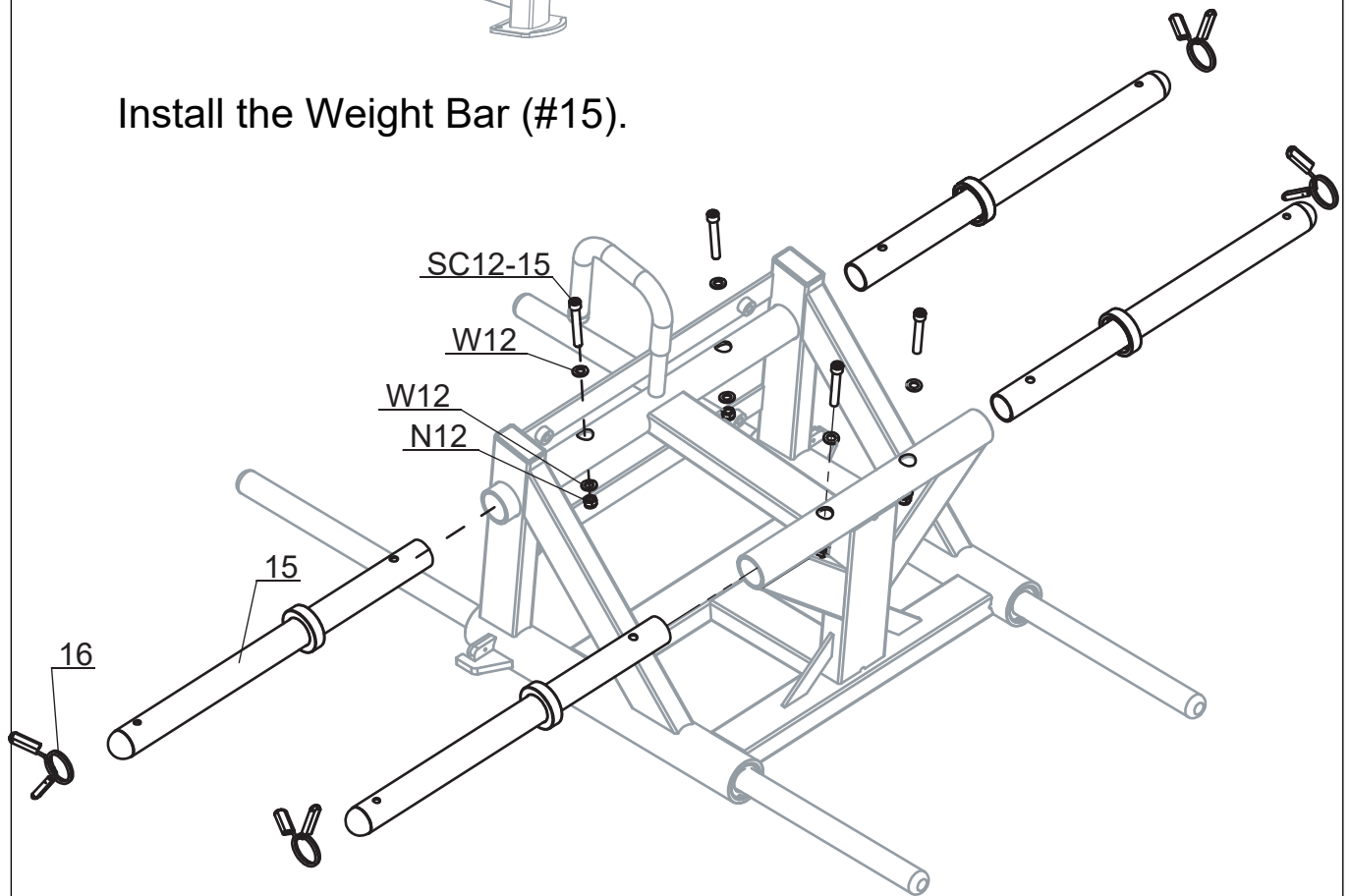

Fixings

W10B
4 PCS

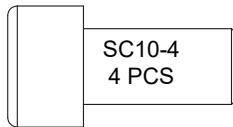

SC10-4
4 PCS

Parts

Part No: 17
Name: Holder Bar
Assy
Q'TY: 1

Part No: 18
Name: Holder Bar
Assy 2
Q'TY: 1

Tools

 8 mm

STEP 8

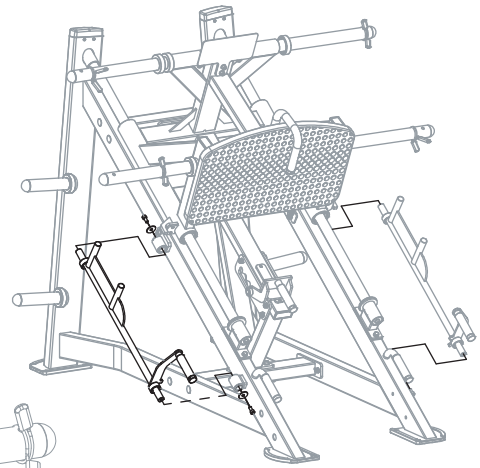

Install The Holder
Bar Assys

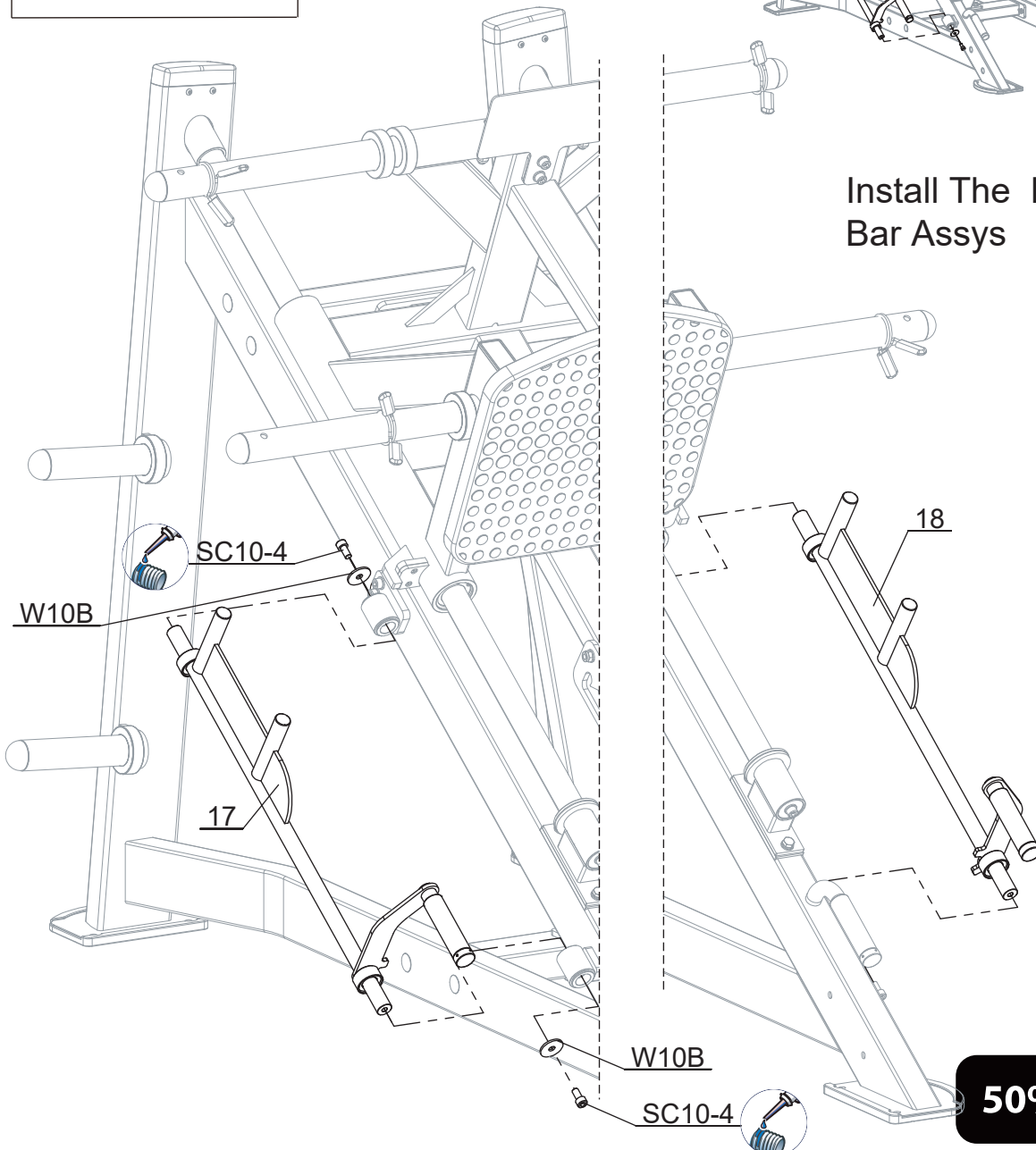

50%



STEP 9

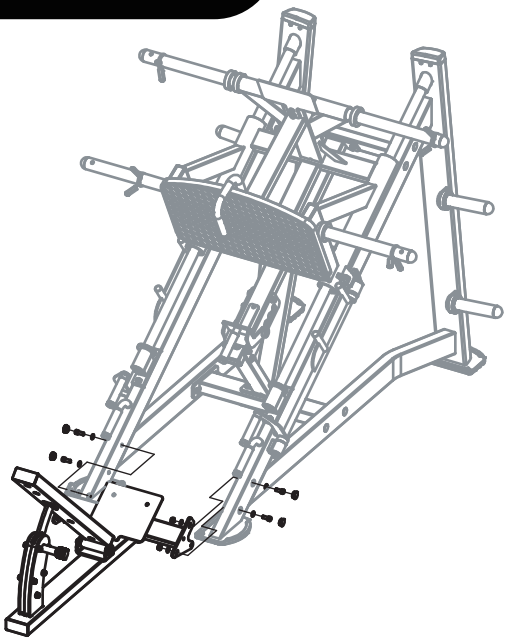

Fixings

- W10 8PCS
- SC10-5 4PCS
- N12 4PCS

Parts

- Part No: 19
Name: Pad Support
Q'TY: 1
- Part No: 5
Name: Hole Cap
Q'TY: 4

Tools

- 17 mm
- 8 mm

Install The Pad Support(#19).

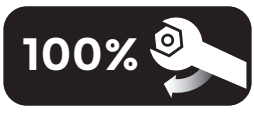
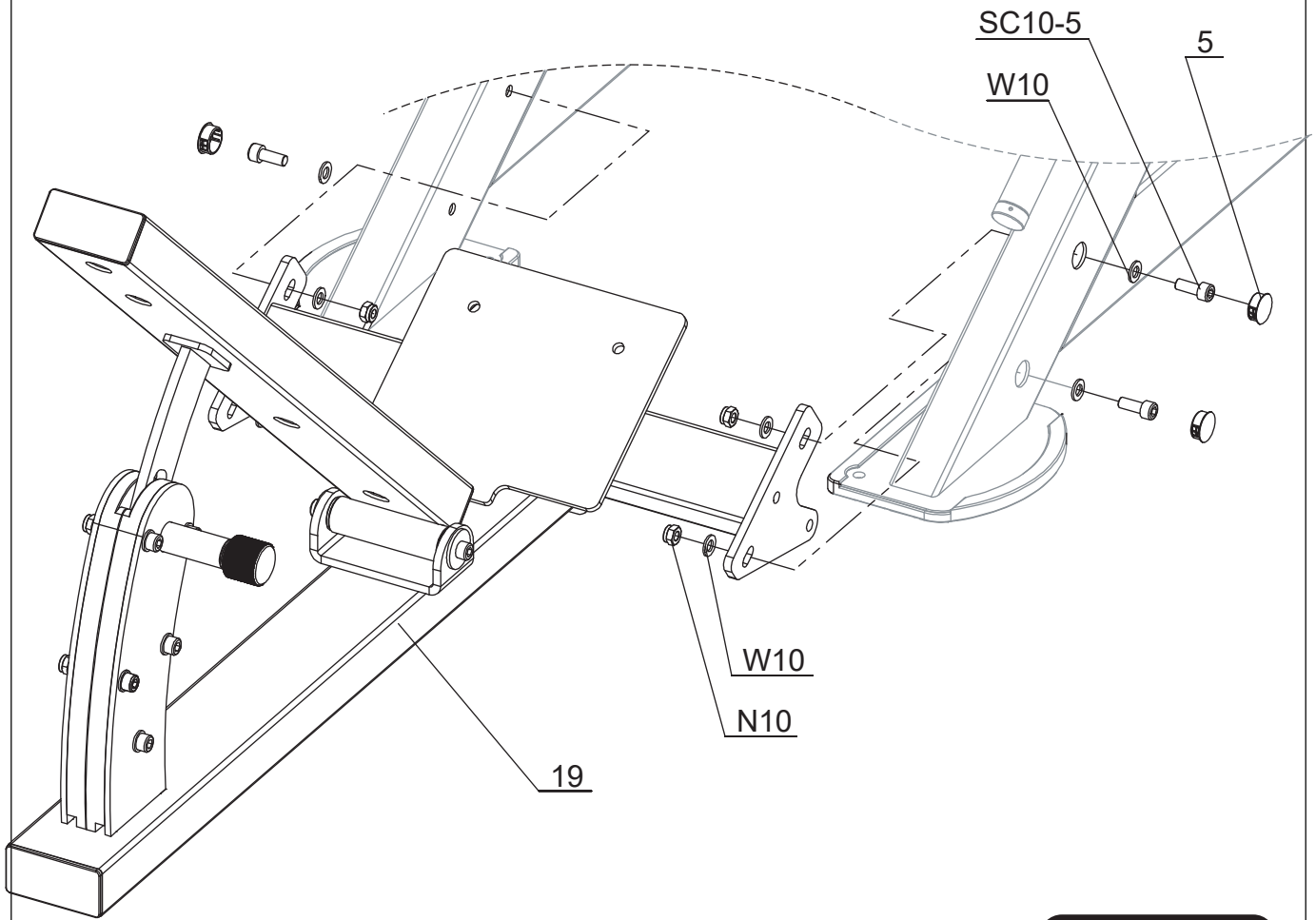

STEP 10

Tools



Parts

- Part No: 5
Name: Hole Cap
Q'TY: 4
- Part No: 21
Name: Head Pad
Q'TY: 1
- Part No: 22
Name: Back Pad
Q'TY: 1
- Part No: 20
Name: Seat Pad
Q'TY: 1

Fixings

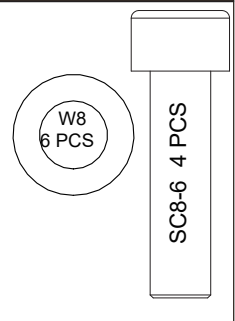

Install The Pads

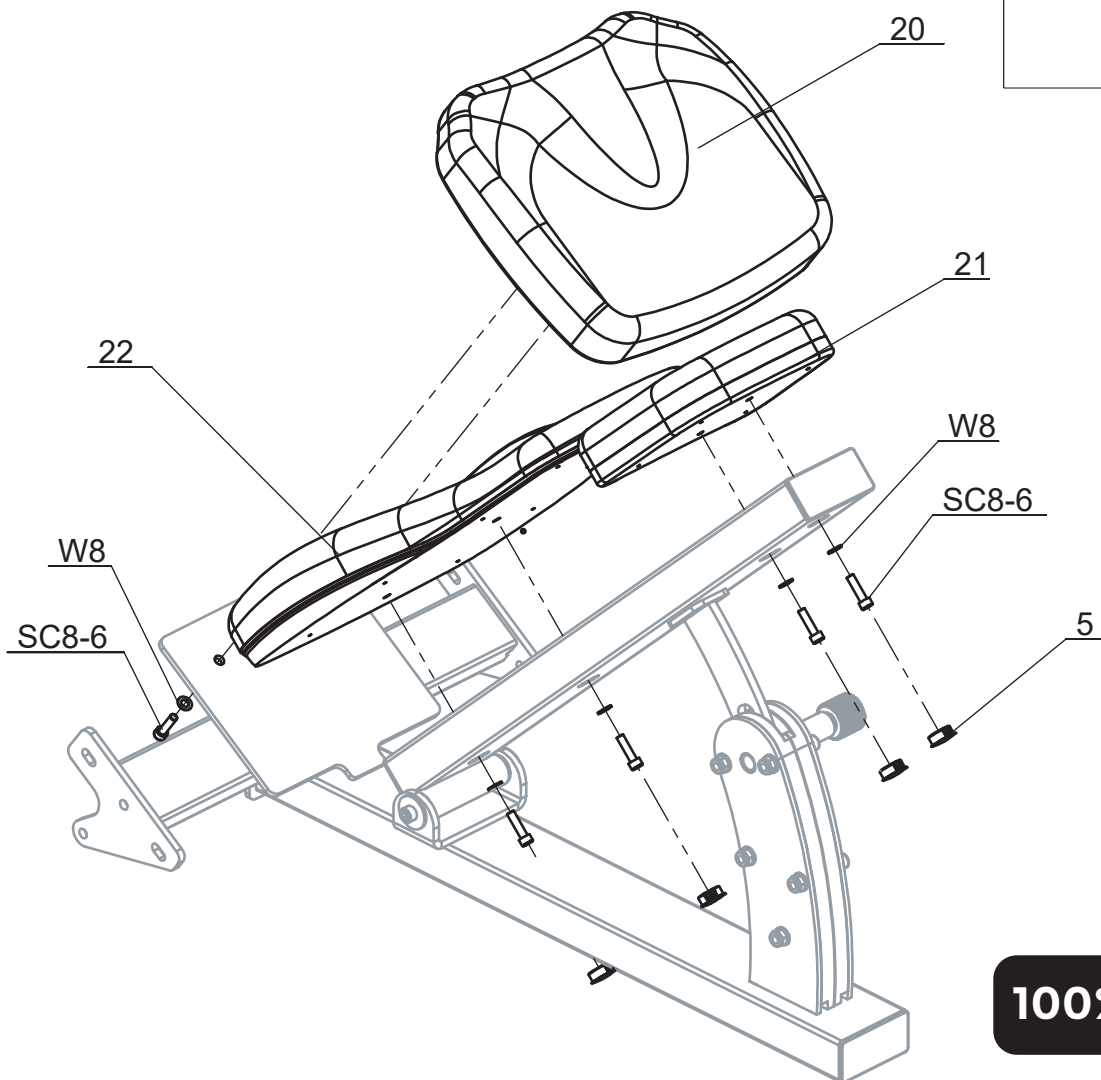
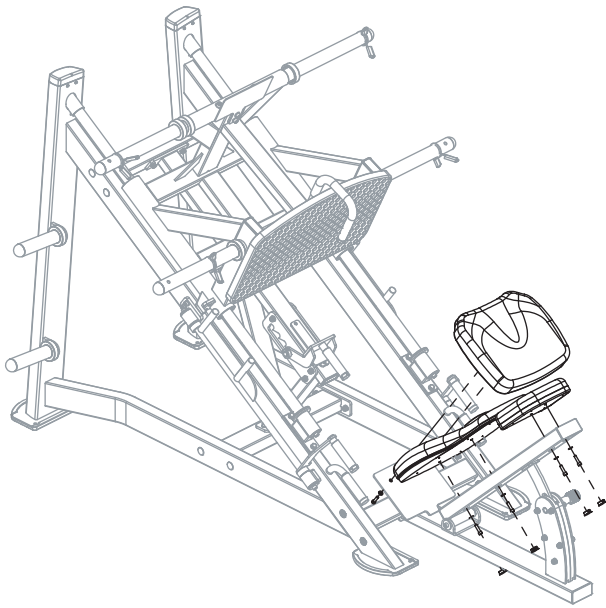

PARTS LIST

PART#	DESCRIPTION	QTY
1	Main Frame 1	1
2	Main Frame 2	1
3	Crosswise Tube 1	1
4	Crosswise Tube 2	1
5	Hole Cap	18
6	Barbell Sleeve	4
7	Pedal Limit Assy	1
8	Pad Plate	1
9	Bushing	2
10	Bumper Pad	2
11	Guide Rod	2
12	Sliding Frame Assy	1
13	Function Board	1
14	Pedal	1
15	Weight Bar	4
16	Barbell Clip	4
17	Holder Bar Assy 1	1
18	Holder Bar Assy 2	1
19	Pad Support	1

PART#	DESCRIPTION	QTY
20	Seat Pad	1
21	Head Pad	1
22	Back Pad	1
N10	Nut M10	16
N12	Nut M12	4
H10-5	Hex Head Bolt M10X25	4
SC8-6	Socket Head Cap Screw M8x30	6
SC10-3	Socket Head Cap Screw M10x16	2
SC10-4	Socket Head Cap Screw M10x20	4
SC10-5	Socket Head Cap Screw M10x25	16
SC10-7	Socket Head Cap Screw M10x35	8
SC10-16	Socket Head Cap Screw M10x80	2
SC12-15	Socket Head Cap Screw M12x75	4
SW10	Spring Washer Φ 10	4
W8	Washer 8	6
W12	Washer 12	8
W10	Washer 10	48
W10B	Big Washer 10	4