

BLK BOX

Preacher Curl Bench

Setup Instructions

⚠ CAUTION: Read all precautions and instructions before using this equipment. Save this manual for future reference.



Table Of Contents

Assembly Instructions.....02-08

Part List.....09

To Apply Thread Locker

The Fasteners marked by the sign  in the following assembling steps need to be bonded to prevent loosening, or the fasteners are a type of thread locking screws.

How to use

1. Degrease and clean surfaces prior to apply adhesive.
2. Insert bolt and apply adhesive to the exposed thread. Assemble nut and tighten to the correct torque (FIG 1).
3. Apply several drops of adhesive down the sides of the blind hole filling the lower third. Apply several drops to the bolt, Assemble and tighten (FIG 2).

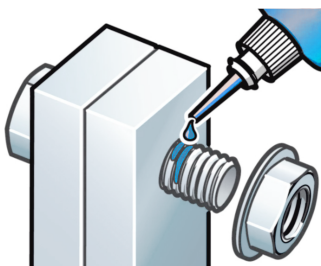

FIG 1

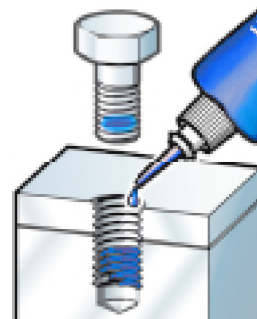
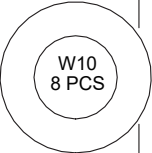

FIG 2

STEP 1

Fixings



SC10-24 4PCS

Parts

Part No:2
Name: Bottom Lateral Tube
Q'TY: 2

Part No:1
Name: Bottom Tube
Q'TY: 1

Tools



17 mm



8 mm

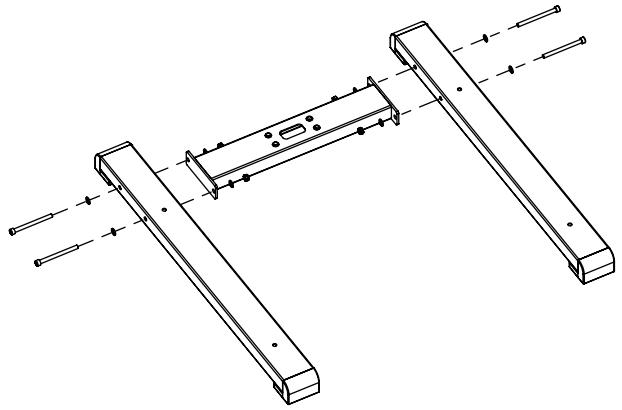

Assemble the Bottom Lateral Tube (#1)
and the Bottom Tube(#2).

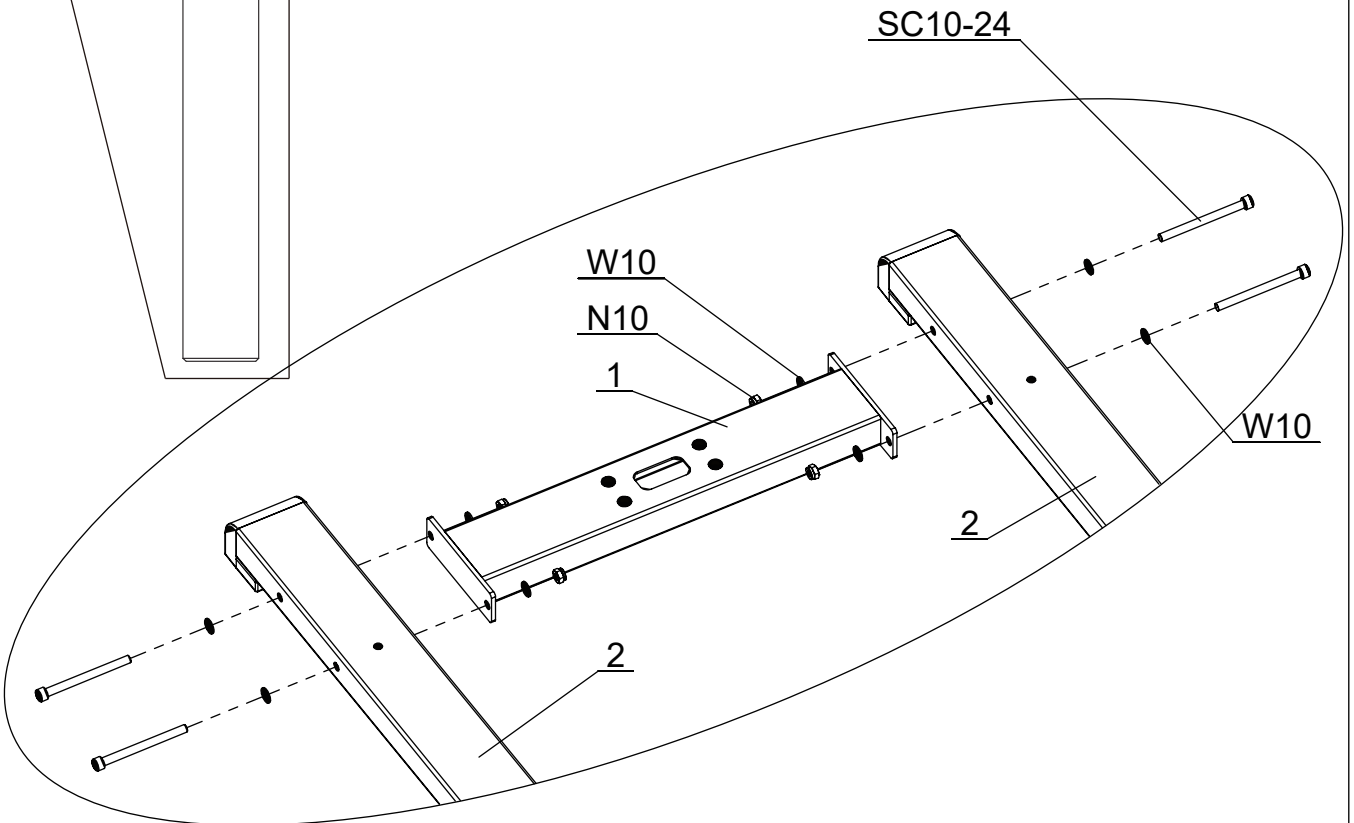

50%



Fixings

SC10-14
4 PCS

N10
4 PCS

W10
4 PCS

W10B
4 PCS

Parts

Part No:3
Name: Elbow Brace
Q'TY: 1

Part No:4
Name: Side Frame
Q'TY: 1

Tools

 17 mm
 8 mm

STEP 2

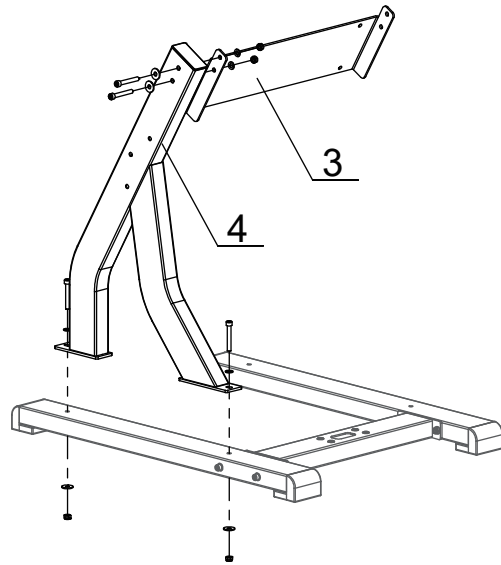

Install The Elbow Brace(#3) And
The Side Frame(#4).

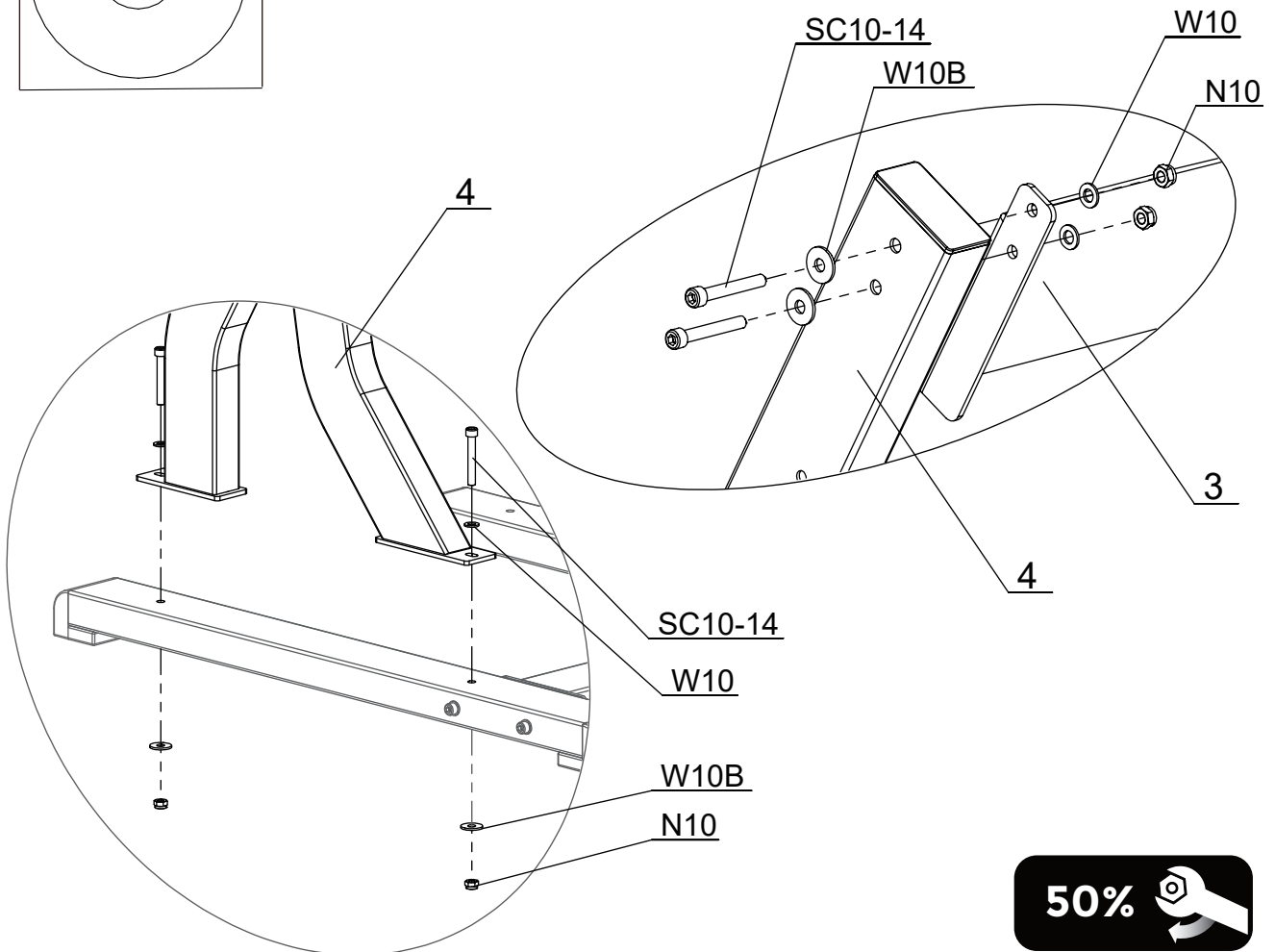

50%



STEP 3

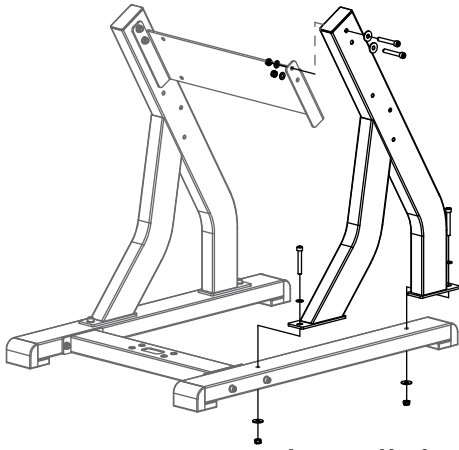

Parts

Part No: 4
Name: Side Frame
Q'TY: 1



Tools



8 mm



17 mm

Fixings

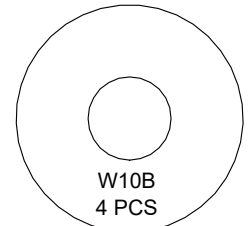
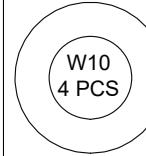

Install the Side Frame (#4).

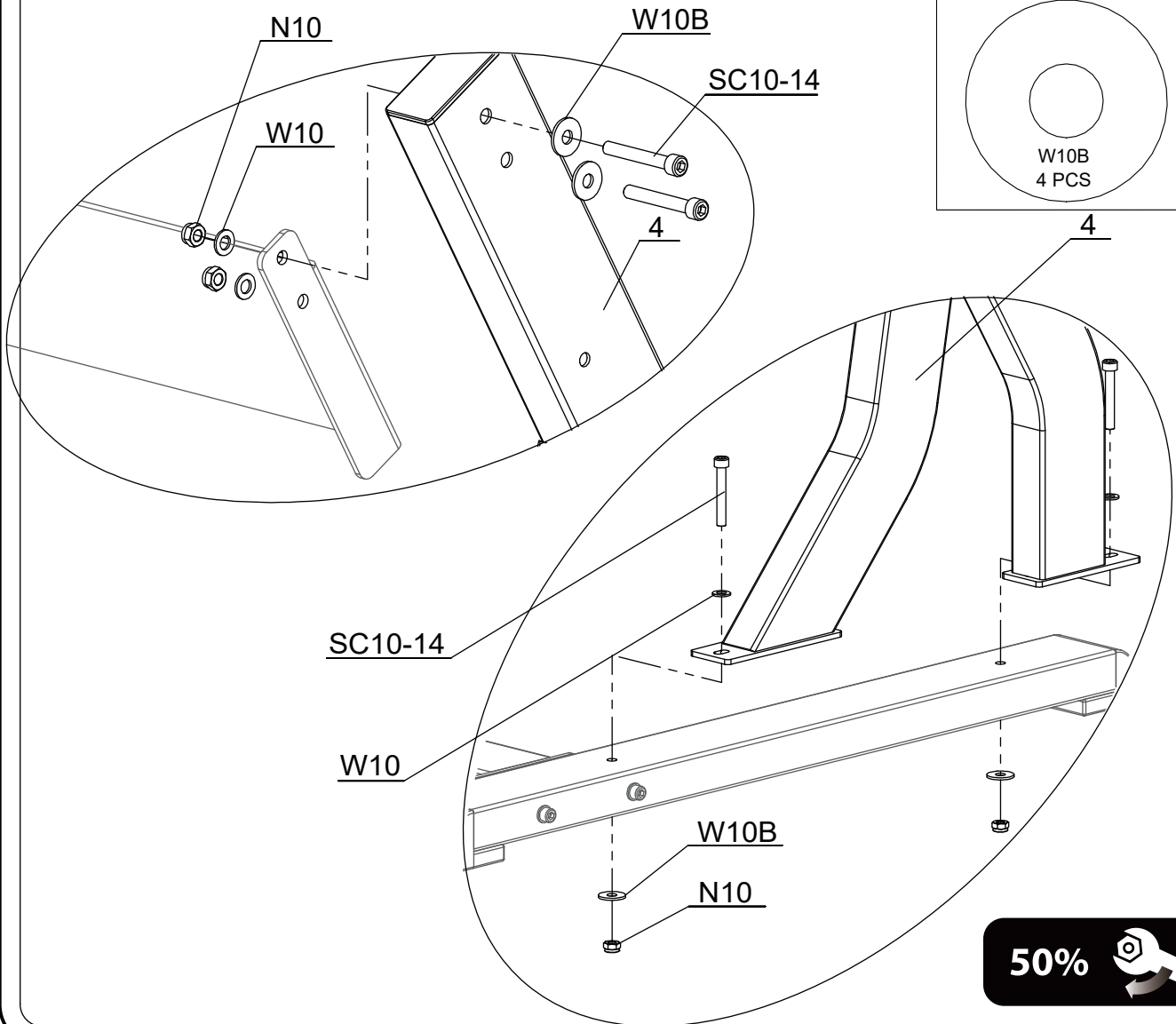

STEP 4

Fixings

- SC10-15
6 PCS
- N10
6 PCS
- W10
6 PCS
- W10B
6 PCS



Parts

Part No: 6
Name: Hook
Q'TY: 2

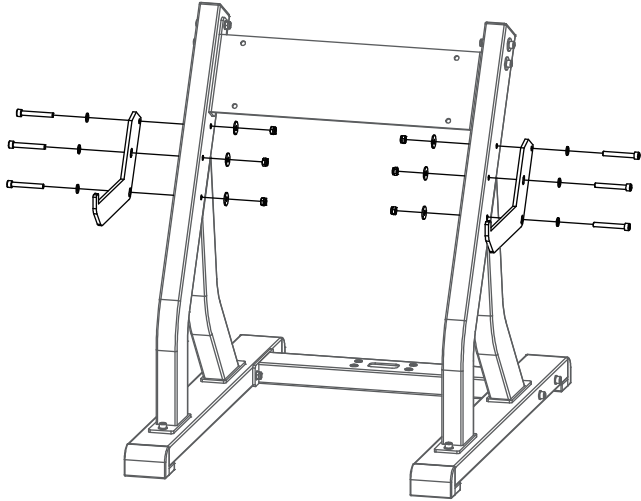

Tools

- 17 mm
- 8 mm



Install the Hook (#6).

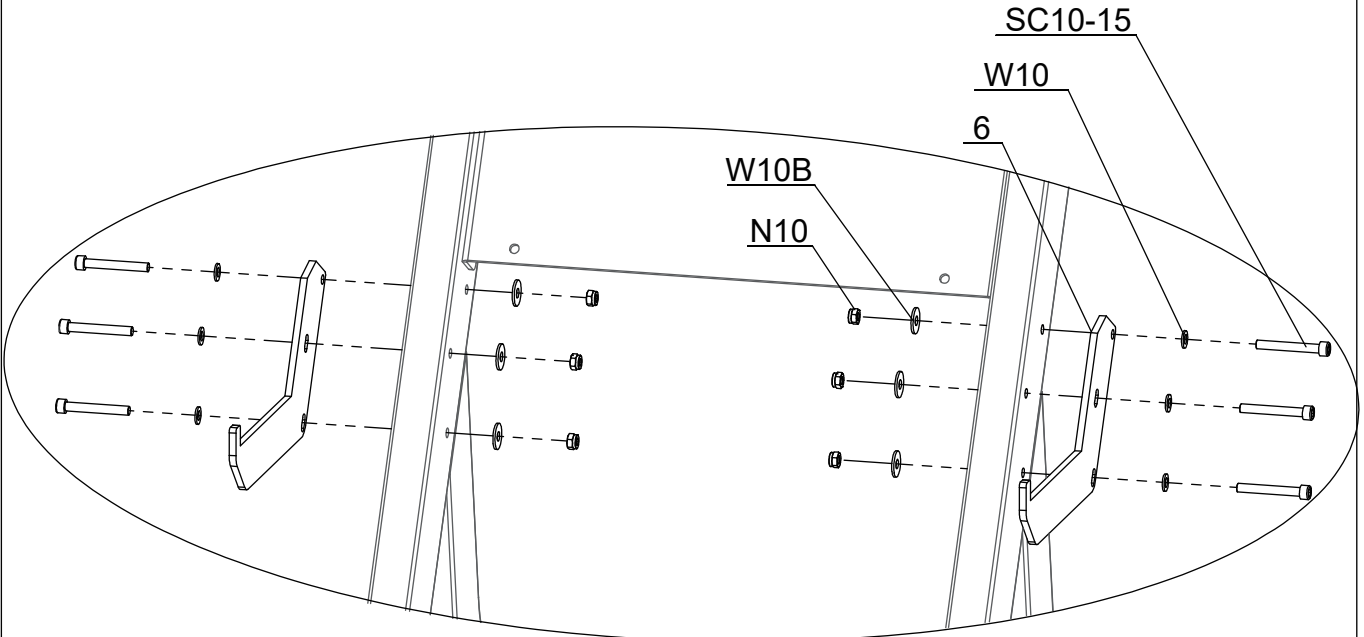

STEP 5

Parts

Part No: 5
Name: Seat Tube
Q'TY: 1



Fixings

SC10-6
4 PCS

W10
4 PCS

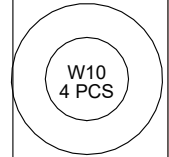

Tools



8 mm

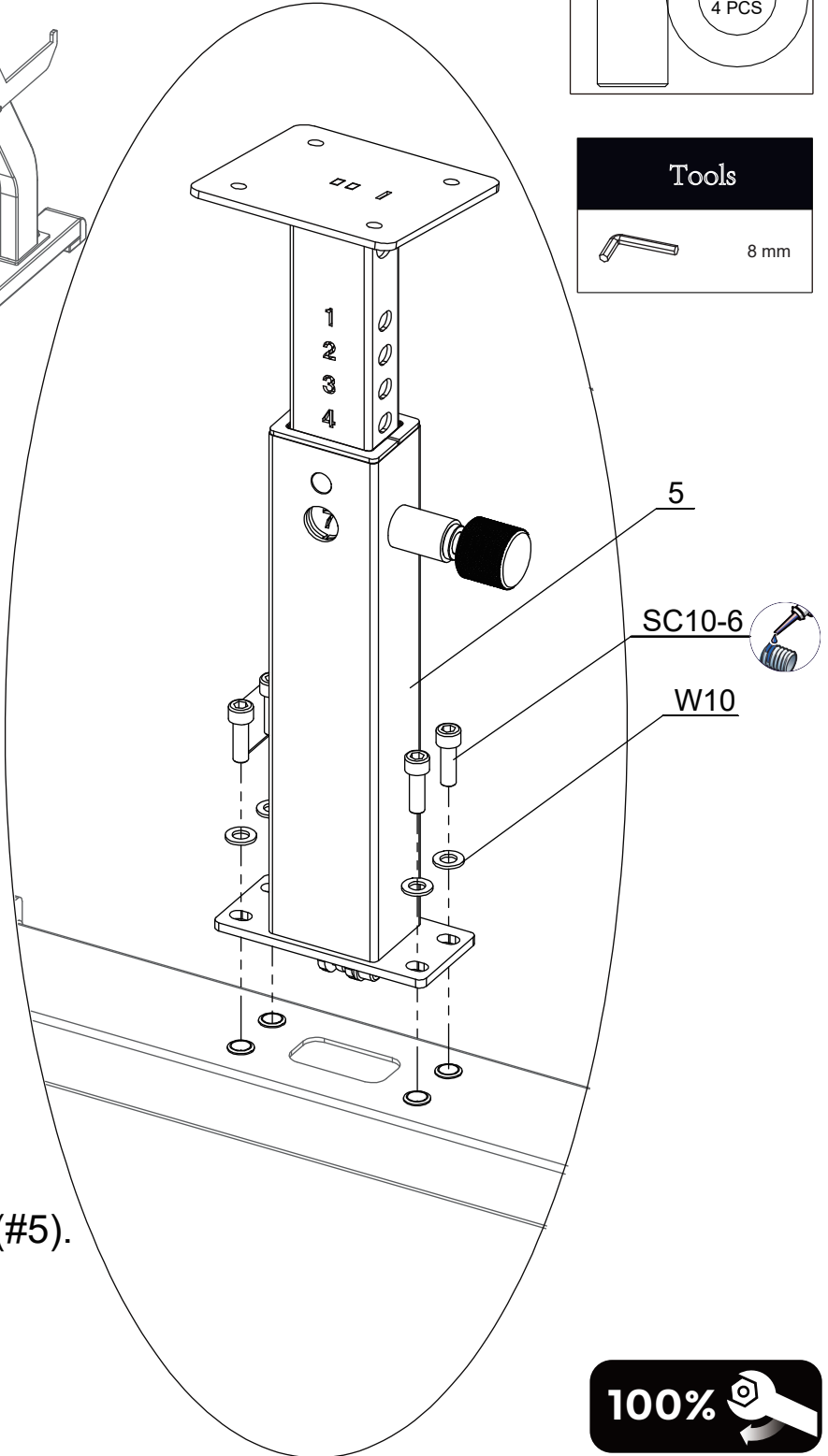
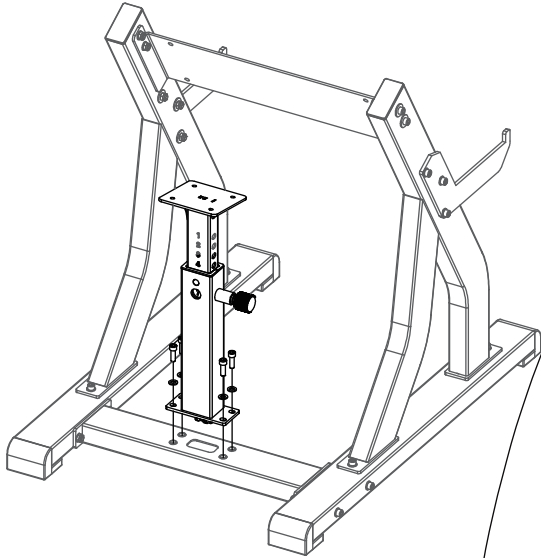

Install the Seat Tube (#5).



STEP 6

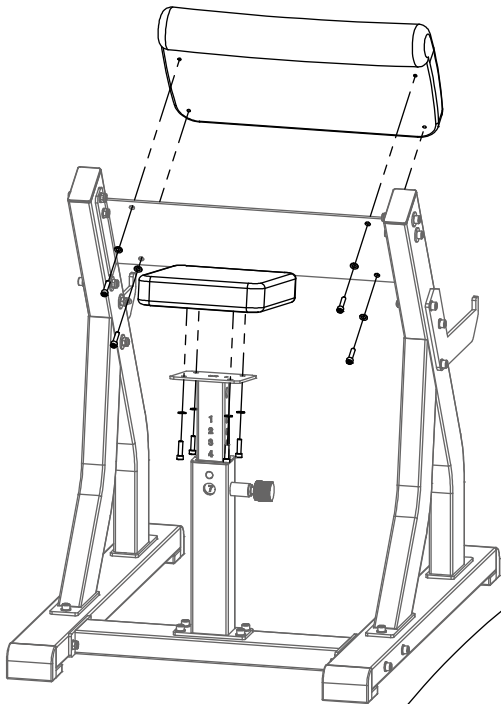

Parts

Part No: 7
Name: Seat Pad
Q'TY: 1



Part No: 8
Name: Elbow Pad
Q'TY: 1

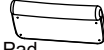

Fixings

SC8-6
8 PCS

W8
8 PCS

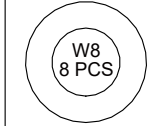

Install the Pad.

Tools



6 mm

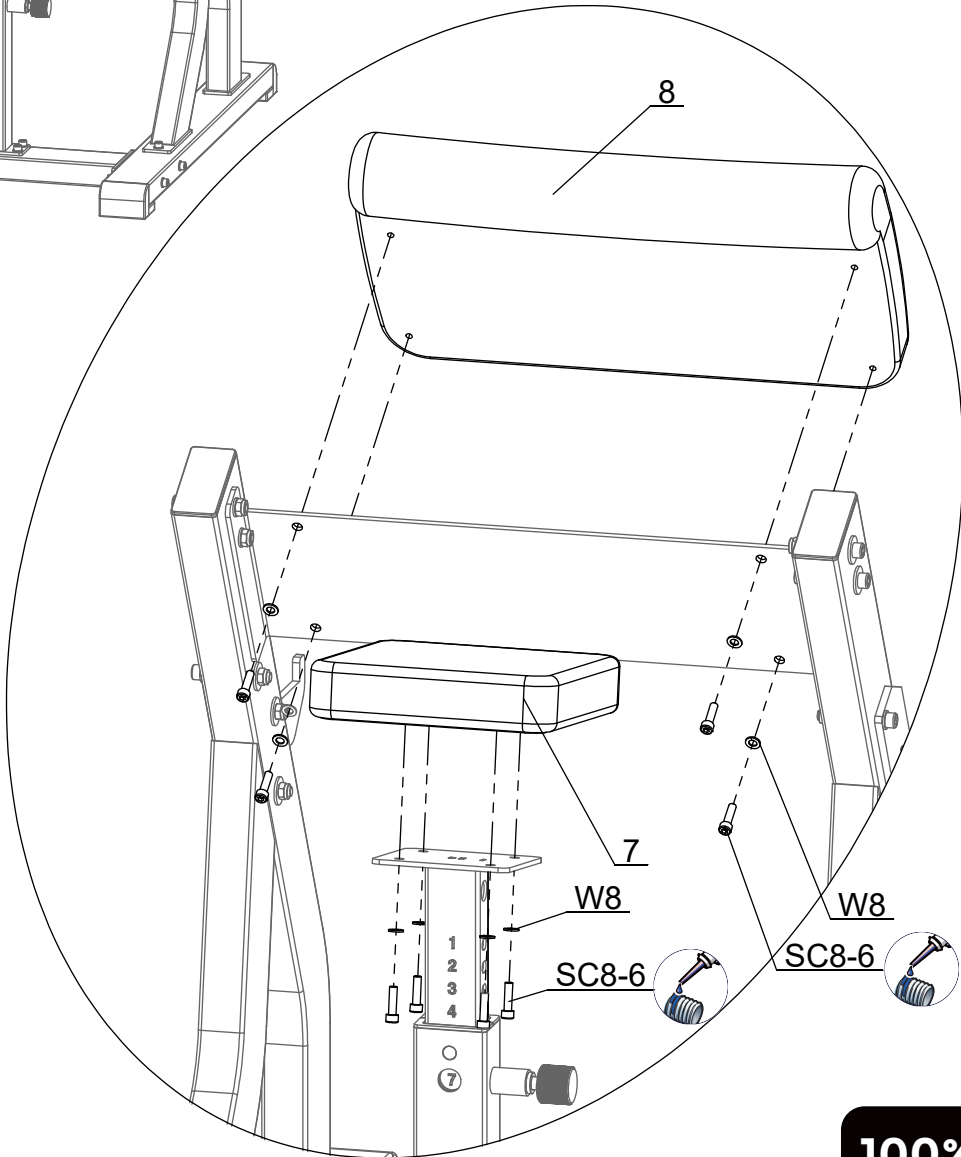

PARTS LIST

PART#	DESCRIPTION	QTY
1	Bottom Lateral Tube	1
2	Bottom Tube	2
3	Elbow Brace	1
4	Side Frame	2
5	Seat Tube	1
6	Hook	2
7	Seat Pad	1
8	Elbow Pad	1
N10	Nut M10	18
SC8-6	Socket Head Cap Screw M8×30	8
SC10-6	Socket Head Cap Screw M10×30	4
SC10-14	Socket Head Cap Screw M10×70	8
SC10-15	Socket Head Cap Screw M10×75	6
SC10-24	Socket Head Cap Screw M10×120	4
W10B	Big Washer 10	14
W8	Washer 8	8
W10	Washer 10	26